

1/8/04

HP SERIES

PORTABLE PUMPS

USER OPERATION AND

MAINTENANCE MANUAL

Pump Serial Number _____



WARNING

Failure to follow the operating, lubrication, and maintenance requirements set forth in this operating and maintenance manual may result in serious personal injury and/or damage to equipment.

A Hale Pump is a quality product: ruggedly designed, accurately machined, carefully assembled and thoroughly tested. In order to maintain the high quality of your pump, and to keep it in a ready condition, it is important to follow the instructions on care and operation. Proper use and good preventive maintenance will lengthen the life of your pump.

ALWAYS INCLUDE THE PUMP SERIAL NUMBER IN CORRESPONDENCE.

HALE PRODUCTS, INC. • A Unit of IDEX Corporation • 700 Spring Mill Avenue • Conshohocken, PA 19428 • TEL: 610-825-6300 • FAX: 610-825-6440
Class 1 • 607 NW 27th Avenue • Ocala FL 34475 USA • Tel: 352-629-5020 800-533-3569 • Fax: 352-629-2902 • www.class1.com

MANUAL P/N 029-0020-24-0, REV E, © 2004 HALE PRODUCTS, INC., PRINTED IN U.S.A.

Hale Products cannot assume responsibility for product failure resulting from improper maintenance or operation. Hale Products is responsible only to the limits stated in the product warranty. Product specifications contained in this material are subject to change without notice.



***HP SERIES
PORTABLE PUMPS***

USER OPERATION AND MAINTENANCE

Table of Contents

1	SAFETY	5
2	EQUIPMENT DESCRIPTION	8
3	OPERATING CONTROL DESCRIPTION	14
4	INITIAL CHECKOUT PROCEDURES	18
5	STARTING PROCEDURES	24
6	SHUTDOWN AND STORAGE PROCEDURES	26
7	MAINTENANCE SCHEDULE	28
8	PUMP MAINTENANCE	29
9	ENGINE MAINTENANCE	32
10	WARRANTY POLICY	42
11	MOUNTING DIMENSIONS	43
12	ELECTRICAL DIAGRAM	49
13	PARTSLIST	51

***HP SERIES
PORTABLE PUMPS***

USER OPERATION AND MAINTENANCE

1 SAFETY

THIS SYMBOL  MEANS WARNING PERSONAL INJURY MAY OCCUR UNLESS INSTRUCTIONS ARE FOLLOWED CAREFULLY.



1. **DO NOT** run engine in an enclosed area. Exhaust gases contain carbon monoxide, an odorless and deadly poison.
2. **DO NOT** check for spark with spark plug or spark plug wire removed. Use an approved tester.
3. **DO NOT** crank engine with spark plug removed. If engine is flooded, place throttle in FAST () position and crank until engine starts.
4. **DO NOT** smoke when filling fuel tank.
5. **DO NOT** fill fuel tank while engine is running. Allow engine to cool for two minutes before refueling.
6. **DO NOT** operate engine when an odor of gasoline is present or other explosive conditions exist
7. **DO NOT** operate engine if gasoline is spilled. Move pump away from the spill and avoid creating any ignition until the gasoline has evaporated.
8. **DO NOT STORE, SPILL, OR USE GASOLINE NEAR AN OPEN FLAME**, or devices such as a stove, furnace, or water heater which utilize a pilot light or devices which can create a spark.
9. **DO NOT** refuel indoors where area is not well ventilated. Outdoor refueling is preferred.
10. Engine produces excessive noise. When pump is operating persons in the immediate vicinity must wear hearing protection.
11. **DO NOT OPERATE ENGINE WITHOUT A MUFFLER**. Inspect periodically and replace if necessary.
12. **DO NOT** operate engine with an accumulation of grass, leaves, dirt or other combustible material in the muffler area.
13. **DO NOT** run engine with air cleaner or air cleaner cover removed.
14. Automatic flow nozzles and tips are designed to work with a minimum

**HP SERIES
PORTABLE PUMPS**

USER OPERATION AND MAINTENANCE

pressure of 7 BAR (100 PSIG). Under normal operation conditions these pumps may not provide the required pressure to use these nozzles properly. When selecting a pump and nozzle combination consideration must also be given to hose lengths and normal friction losses.

15. TO PREVENT ACCIDENTAL STARTING

when servicing the engine or pump always disconnect the negative wire from battery terminal.

CAUTION

1. Engine is shipped without oil in the crankcase. Before placing pump into operation for the first time fill engine to proper level with SAE 30 Weight Detergent oil.

2. HP100 gearbox is shipped without oil. Before placing pump into operation for the first time fill gearbox to proper level with SAE 30 Weight Detergent oil.

3. **DO NOT** tamper with governor springs, governor links or other parts which may increase the governed engine speed.

4. **DO NOT** tamper with the engine speed selected by the original equipment manufacturer.

5. **DO NOT** touch hot mufflers, cylinders, or fins as contact may cause burns.

6. **DO NOT** place hands or feet near moving or rotating parts.

7. **DO** keep cylinder fins free of debris as this can affect engine speed.

8. Pull starter cord slowly until resistance is felt. Then pull cord rapidly to avoid kickback and prevent hand or arm injury.

9. The pump and motor assembly are vibration isolated. When making the permanent connections to the suction and discharge fittings **DO NOT** use hard piping. A short length of flexible piping is required to prevent damage to the pump and engine.

10. Always connect the black wire to the negative battery terminal last.

11. The pump and motor assembly are vibration isolated. When making the permanent connections to the suction and discharge fittings **DO NOT** use hard piping. A short length of flexible piping is required to prevent damage to the pump and engine.

12. Do not run pump for more than 45 seconds without suction established.

13. Petroleum solvents, such as kerosene, are not to be used to clean cartridge. They may cause deterioration of the cartridge. **DO NOT OIL CARTRIDGE. DO NOT USE PRESSURIZED AIR TO CLEAN OR DRY CARTRIDGE.**

14. For proper engine operation, keep controls and linkages clean and free of debris.

15. Periodically clean muffler area to remove all grass, paper, leaves, dirt or other combustible debris.

16. Sparking can occur if wire terminal does not fit firmly on spark plug. Reform terminal if necessary.

17. Exhaust system components may smoke during the initial break-in period. This smoking will stop after the pump is run several times.

2 EQUIPMENT DESCRIPTION

The HP Series Portable Pump line provides emergency services personnel around the world with portable pumps to fulfill many types of in-service applications. The pumps are available in configurations providing a wide range of pressures and flows to suit user requirements in a lightweight portable unit.

The pumps are available as four separate models, the Model HP100 Attack Pump, Model HP200 Combination Pump, Model HP300 Supply Pump and Model HP400 Transfer Pump. The HP100 Attack Pump is rated to supply water at flows and pressures that are suitable for extinguishing fires. The HP200 Combination Pump is a dual purpose pump that provides the capability to attack fires and/or supply water from an emergency water source. The HP300 Supply Pump is used to supply water from an emergency water source. The HP400 Transfer Pump is a high volume pump that is suitable for transferring large volumes of water at low pressures.

A standard feature of each pump configuration includes pump ends made of strong corrosion resistant aluminum alloy held together with a

stainless steel clamp. The pump engine is air cooled and the portable models are enclosed with high strength thermoplastic covers that ensure a clean appearance and quiet operation. The aluminum parts of the discharge valves are treated with a hard anodizing process to increase corrosion resistance and durability. The molded plastic fuel tank is an integral part of the pump base therefore there is only one item to carry, other than the required suction and discharge hoses, when the pump is to be placed into service. An aluminum skid plate on the bottom of the pump assembly provides extra puncture protection for the fuel tank.

In addition to the standard portable HP series pumps an "X" model, without the plastic covers, carrying handles or subframe, is available that can be permanently mounted to the apparatus frame.

Also available is the "I" model, which has no plastic covers or subframe. The pump and engine are mounted to a steel skid base which can easily be fitted to optional carrying handles. The pump can also be permanently mounted and comes complete with a remote 3 gal (12 liter) fuel tank.

Each pump is powered by a reliable state-of-the-art air cooled, 18 HP, V-twin, Overhead Valve (OHV) engine. The engine has electric start with a recoil backup to ensure starting under all circumstances. The integral fuel tank provides 12 liters (3 gallons) of fuel and will permit the pump to run for 2 hours at rated performance conditions, but under many operating conditions longer run times can be obtained.

Each portable pump is equipped with

four folding handles. Other than the stowed position there are two other positions of the handles to provide for increased mobility by two people when moving the pump. When not in use the handles fold away to provide a sleek appearance and prevent equipment or personnel from getting caught on them. Also when the handles are folded the pump is more compact and will fit in a smaller storage compartment.

The discharge valve on the portable pump version swivels through 175° for

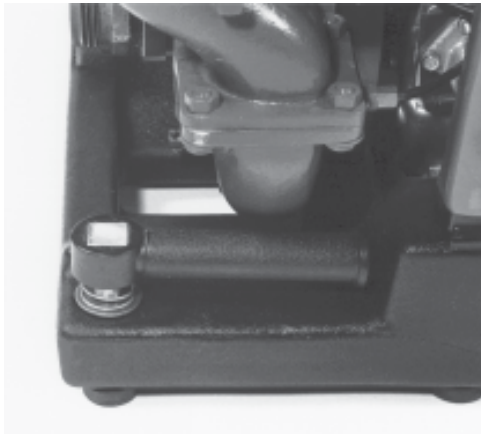

FOLDED FOR STORAGE

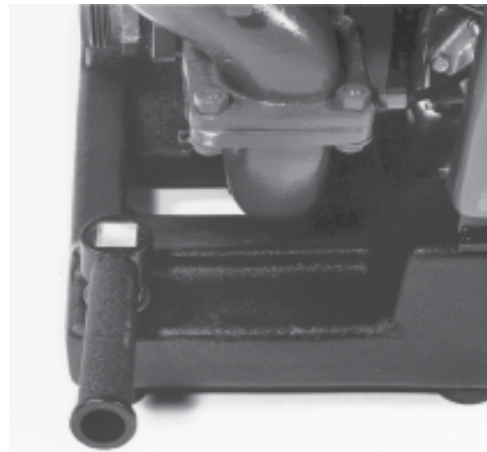

EXTENDED TO SIDE

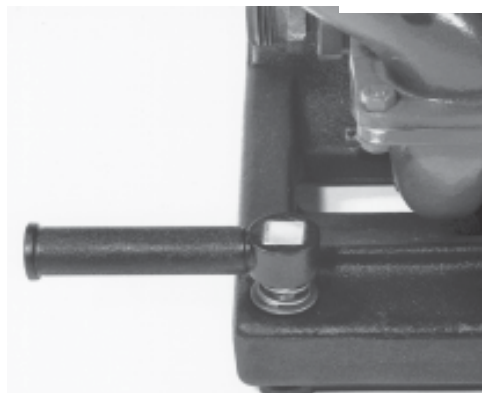

EXTENDED TO END
PORTABLE PUMP HANDLE POSITIONS

**HP SERIES
PORTABLE PUMPS**

USER OPERATION AND MAINTENANCE

ease of discharge hose connection. The unique valve permits the discharge to be directed in any direction without disturbing the position of the pump. The valve is a self checking type that automatically closes to form a positive seal when priming the pump.

Each portable pump is provided with a marine grade quick connect electrical socket. This socket is used to power the optional light mast for night time operations. The same electrical socket can also be used to connect a trickle charger to ensure the battery is charged and the pump is always in a ready state.

The HP series pump line has been designed to meet stringent requirements. The curves that follow are the expected performance that can be obtained from that specific pump model. All the tests were conducted at sea level.

NOTICE
Performance of HP Series pumps meets or exceeds NFPA1921 requirements. For complete NFPA1921 compliance, the pumping units must be marked with specific labels. Consult factory if these labels are required.

EQUIPMENT SPECIFICATIONS

ENGINE:
MAKE: BRIGGS AND STRATTON VANGUARD™
MODEL: 350447 Series
TYPE: Horizontal Shaft, Air Cooled, V-Twin, OHV
HORSEPOWER: 18 BHP (13.4 kW) at 4000 RPM
TORQUE: 40.7 N-m (30 ft-lb) Max. at 2600 RPM
BORE x STROKE: 72 x 77 mm (2.83 x 2.75 in)
DISPLACEMENT: 570 cc (34.75 cu in)
OIL CAPACITY: 1.4 liter (3.0 pint)
FUEL TANK: Cross linked Polyethylene
FUEL CAPACITY: 12 liters (3 gallons)
ELECTRICAL: 16 AMP Alternator
EMISSIONS: Meets 1994 California Air Resources Board (CARB) Standards

The serial number of each pump assembly is located on a tag attached to the engine shroud near the recoil starter pull handle. The following figure shows the serial number tag.

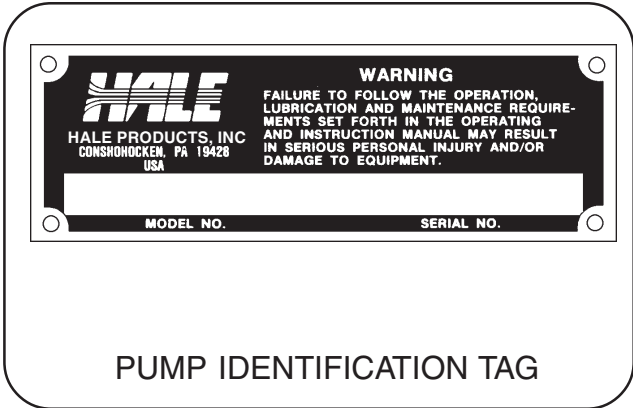

HP SERIES PORTABLE PUMPS

USER OPERATION AND MAINTENANCE

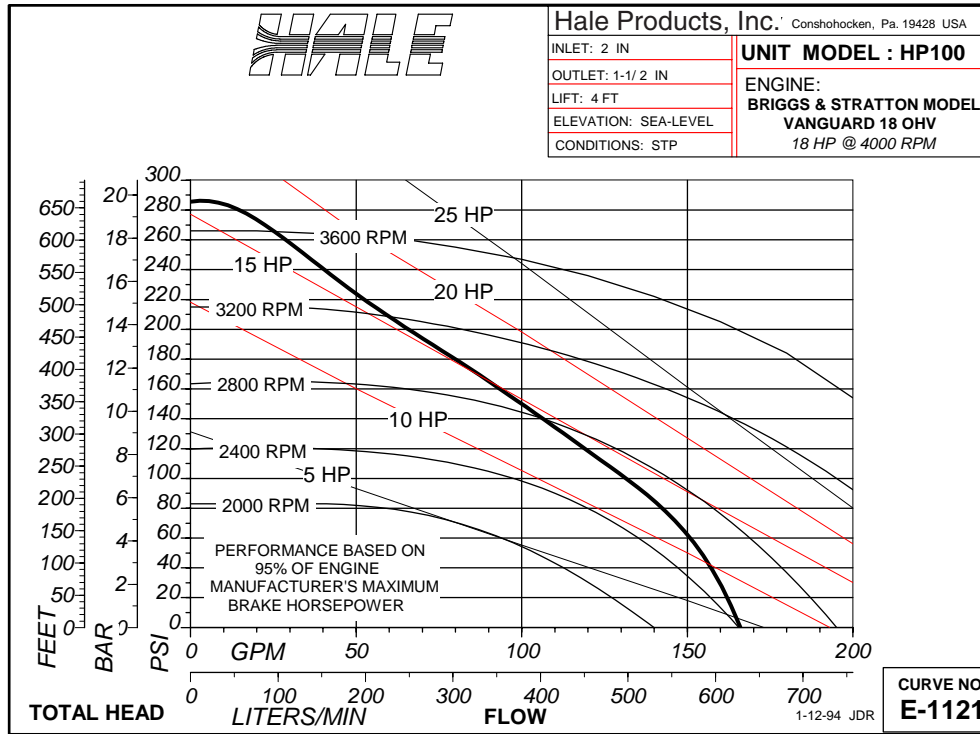

HP100 SERIES PERFORMANCE CURVE

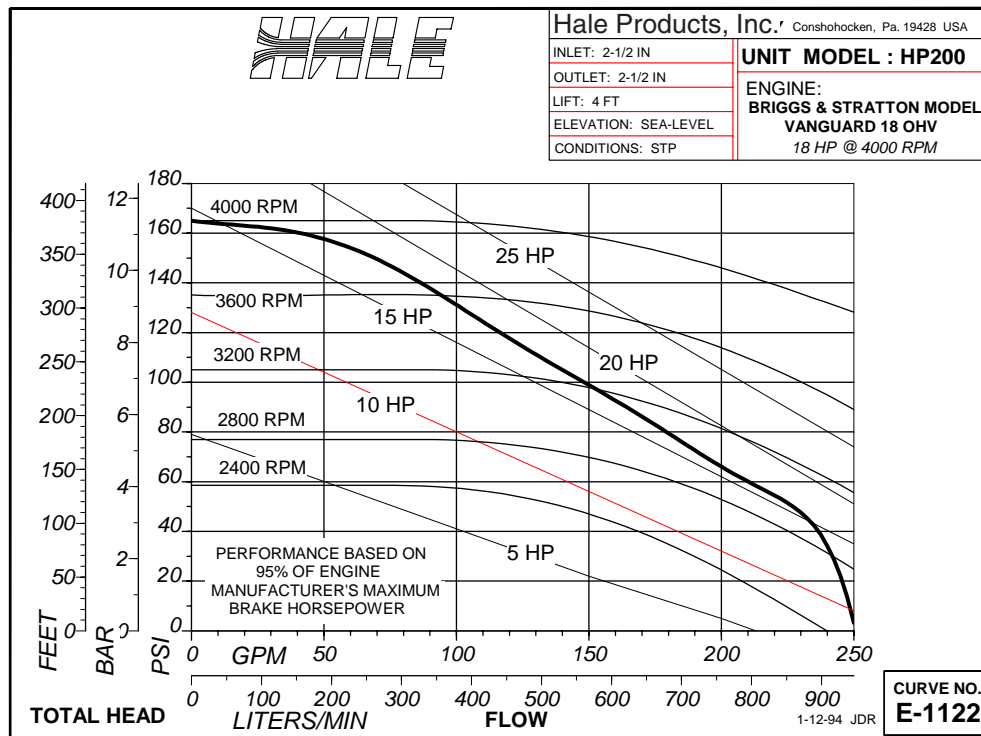

HP200 SERIES PERFORMANCE CURVE

**HP SERIES
PORTABLE PUMPS**

USER OPERATION AND MAINTENANCE

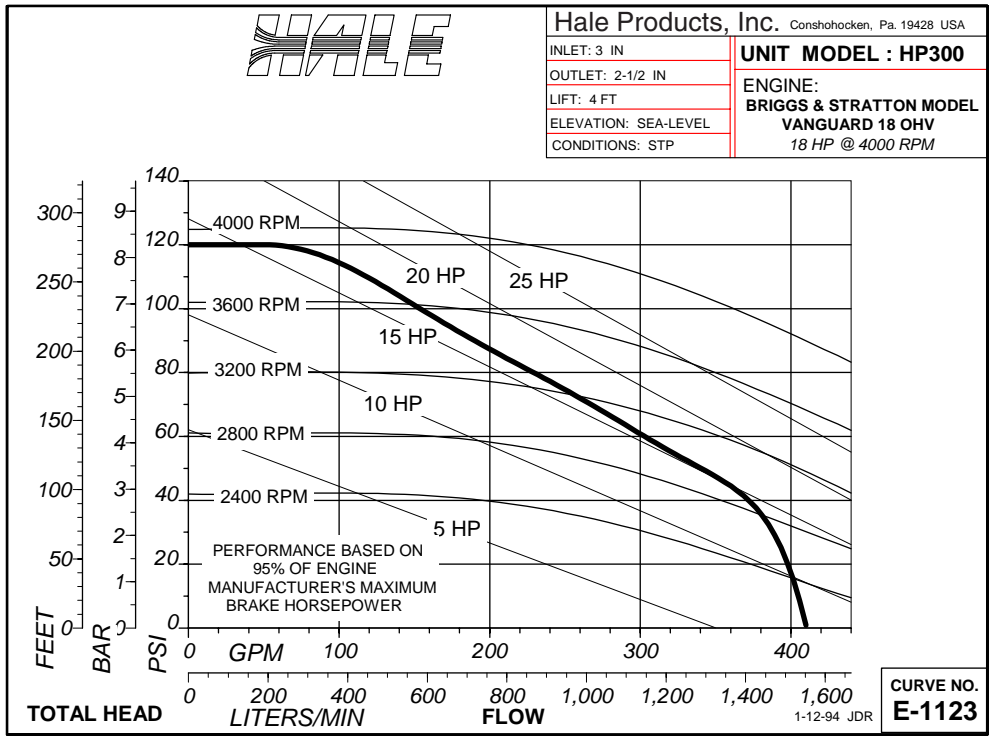

HP300 SERIES PERFORMANCE CURVE

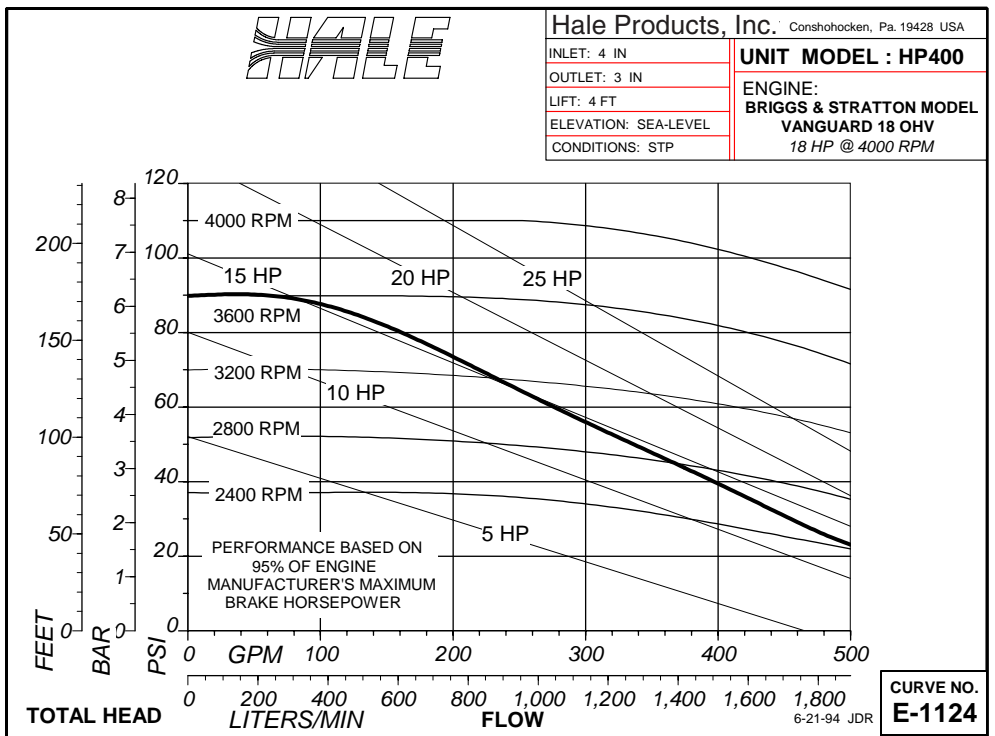

HP400 SERIES PERFORMANCE CURVE

**HP SERIES
PORTABLE PUMPS**

USER OPERATION AND MAINTENANCE

PUMP MODEL	100	200	300	400
TYPE	ATTACK	COMBINATION	SUPPLY	TRANSFER
SUCTION CONNECTION (Note 1)	2 inch NPT Female	3 inch NPT Female (4 inch Victaulic)	3 inch NPT Female (4 inch Victaulic)	3 inch NPT Female (4 inch Victaulic)
DISCHARGE CONNECTION (Note 1)				
HP PORTABLE	2 in. ISO Female	2-1/2 in. ISO Female	2-1/2 in. ISO Female	2-1/2 in. ISO Female
HP "X" SERIES	1-1/2 in. NPT Female	2-1/2 in. NPT Female (Hale 115 Flange)	3 in. NPT Female (Hale 115 Flange)	3 in. NPT Female (Hale 115 Flange)
BODY	ALUMINUM	ALUMINUM	ALUMINUM	ALUMINUM
IMPELLER				
MATERIAL	SILICON BRONZE	SILICON BRONZE	SILICON BRONZE	SILICON BRONZE
DIAMETER	123.83 mm (4.875 in.)	222.25 mm (8.75 in.)	203.20 mm (8.00 in.)	184.15 mm (7.25 in.)
SHAFT	STAINLESS STEEL	ENGINE SHAFT WITH BRONZE SLEEVE	ENGINE SHAFT WITH BRONZE SLEEVE	ENGINE SHAFT WITH BRONZE SLEEVE
BEARING	BALL	N/A	N/A	N/A
PRIMING	EXHAUST VENTURI	EXHAUST VENTURI	EXHAUST VENTURI	EXHAUST VENTURI
MAXIMUM FLOW AT RATED PRESSURE	568LPM @ 3.5BAR 150 GPM @ 50 PSI	852LPM @ 3.5BAR 225 GPM @ 50 PSI	1514LPM @ 1.4BAR 400 GPM @ 20 PSI	1893LPM @ 1.4BAR 500 GPM @ 20 PSI
MAXIMUM PRESSURE, BAR (PSI)	20 BAR (290 PSI)	11 BAR (165 PSI)	8 BAR (120 PSI)	6 BAR (90 PSI)
"X" SERIES				
LENGTH	635 mm (25 in.)	635 mm (25 in.)	635 mm (25 in.)	635 mm (25 in.)
WIDTH	438 mm (17-1/4 in.)	438 mm (17-1/4 in.)	438 mm (17-1/4 in.)	438 mm (17-1/4 in.)
HEIGHT	543 mm (21-1/4 in.)	543 mm (21-1/4 in.)	543 mm (21-1/4 in.)	543 mm (21-1/4 in.)
WEIGHT	75 kg (165 Lbs)	66 kg (146 Lbs)	67 kg (148 Lbs)	67 kg (148 Lbs)
PORTABLE SERIES				
LENGTH				
Handles Extended	892 mm (35-1/8 in.)	892 mm (35-1/8 in.)	892 mm (35-1/8 in.)	892 mm (35-1/8 in.)
Handles Folded	635 mm (25 in.)	635 mm (25 in.)	635 mm (25 in.)	635 mm (25 in.)
WIDTH				
Handles Extended	698.5 mm (27-1/2 in.)	698.5 mm (27-1/2 in.)	698.5 mm (27-1/2 in.)	698.5 mm (27-1/2 in.)
Handles Folded	498.5 mm (19-5/8 in.)	498.5 mm (19-5/8 in.)	498.5 mm (19-5/8 in.)	498.5 mm (19-5/8 in.)
HEIGHT	587 mm (23-1/8 in.)	587 mm (23-1/8 in.)	587 mm (23-1/8 in.)	587 mm (23-1/8 in.)
WEIGHT	88 Kg (194 Lbs)	80 Kg (176 Lbs)	80 Kg (176 Lbs)	84 Kg (185 Lbs)

Note 1: Standard threads machined into the pump body and valve for the particular model. When ordering pump specify suction and discharge adapter required for specific needs. With the exception of Storz adapters, the adapters will be factory installed prior to pump delivery

3 OPERATING CONTROL DESCRIPTION

Most of the controls and indicators necessary for the operation of the pump are located on the operator panel. The pump operator should become thoroughly familiar with the location and function of all pump controls and indicators before attempting operation of the pump.

The "I" version uses engine mounted controls that are explained in the enclosed Briggs and Stratton engine manual.

The controls and indicators along with their functions are as follows:

1. **THROTTLE LEVER:** The throttle lever is located on the left side of the instrument panel and controls the speed at which the pump operates to obtain the required flow. The lever is a slide type "T"-handle that is infinitely adjustable from SLOW (🐢) to FAST (🐇).

2. **MASTER SWITCH:** The Master switch is located below the start button and is used to close the electrical circuits on the pump to enable operation. This is a rocker type switch which when the (○) side is depressed energizes the electrical system to enable pump operation. When the (—)side is depressed the electrical system is disconnected and the pump stops.

3. **START BUTTON (🔌):** The start button is located to the right of the throttle lever and is used to start the engine. Depressing the button after the master switch is placed in the on (—) position will engage the electric starter on the pump engine. After the button is released the button will return to the normal position to disengage the starter.

4. **PRIMING LEVER (🔌):** The Priming Lever is a "T" type handle located to the right of the start switch and master switch and is used to engage the exhaust primer when the pump is started. Pulling the "T" handle down will engage the primer. Due to spring force

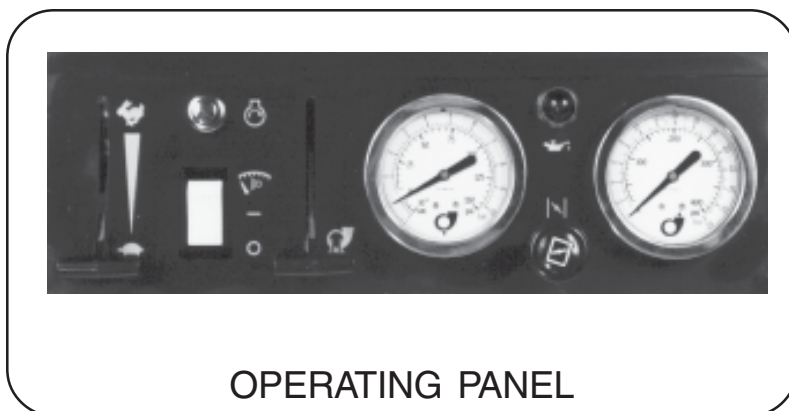

the handle must be held in the down position until the pump is primed. Once the pump is primed and pressure is showing on the discharge pressure gauge the "T" handle is released and returns to the up position by spring force for normal pump operation.

The base "I" version uses a knob (located above the throttle control) which is pulled to engage the primer.

5. SUCTION GAUGE: The suction gauge is located in the center of the instrument panel and provides the operator with an indication of the water pressure on the suction side of the pump. The suction gauge is a compound gauge that reads from -1 to 10 BAR (30 in. Hg vac to 150 PSIG).

6. LOW OIL PRESSURE LIGHT (🛑): The low oil pressure light is located to the right of the discharge gauge and is connected to the oil pressure switch located on the oil filter adapter. When the master switch is first energized the low oil pressure light will light to indicate the pump power is on. After the pump starts and oil pressure builds up the light will go out to indicate there is sufficient oil pressure in the engine. The engine is equipped with an oil pressure switch that activates the low oil pressure light when pressure drops to

0.2-0.4 kg/cm² (4-6 PSIG). If the light should light during normal operation the operator must shutdown the engine immediately to avoid engine damage.

7. CHOKE CONTROL (🛑): The choke control is located below the oil light and is used to control the air fuel mixture in the carburetor when starting the engine. Pulling the choke control out will engage the choke. After the pump starts pushing in on the choke control will gradually disengage the choke and allow normal operation.

8. DISCHARGE GAUGE: The discharge gauge is located to the right of the priming lever and provides the operator with an indication of the pump discharge pressure. The gauge reads from 0 to 28 BAR (0 to 400 PSIG).

9. FUEL PRIMER: The fuel primer is located on the back side of the pump engine behind the protective cover of the HP series pumps. The fuel system requires priming only when starting the pump after fuel is put into the tank initially or if the pump has run out of fuel. Priming is accomplished by squeezing the fuel primer bulb until firm.

**HP SERIES
PORTABLE PUMPS**

USER OPERATION AND MAINTENANCE

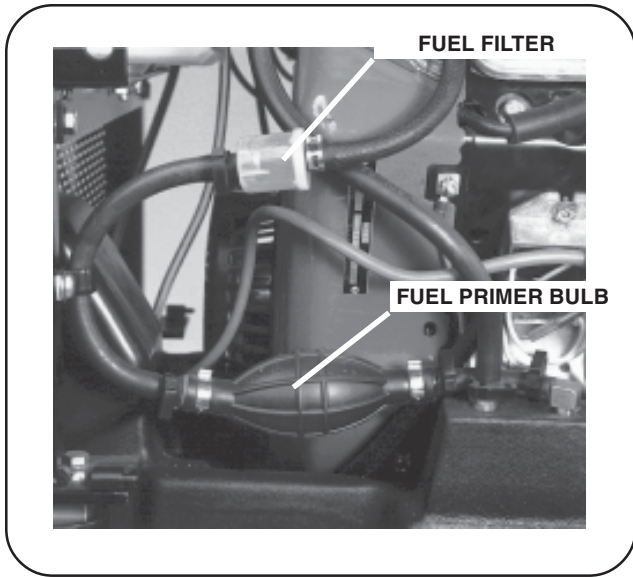

10. **RECOIL STARTER:** The recoil starter is located on the engine behind the protective grill. To gain access to the recoil starter the pump panel below the instrument panel must be opened on the portable models.

11. **PUMP DRAIN:** The pump drain is a petcock type valve located below the suction connection of the pump

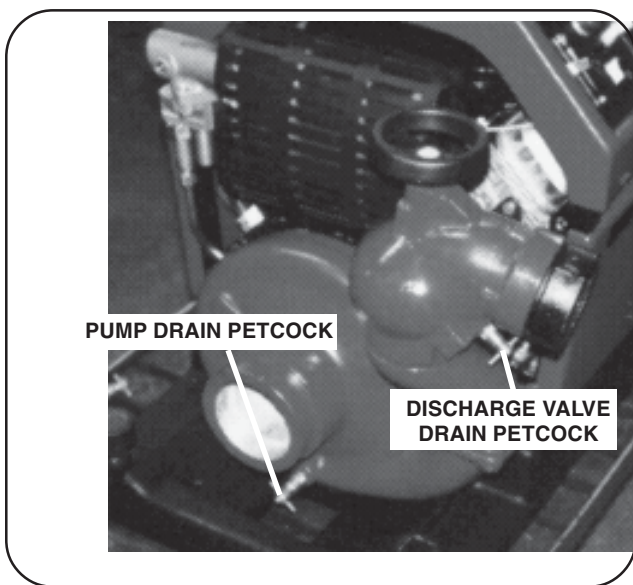

at the lowest point of the pump volute. This valve is used to drain all water from the pump after use and prior to storage.

12. **DISCHARGE VALVE DRAIN:** The discharge valve drain is a petcock type valve located below the outlet of the discharge valve. This valve is used to relieve the pressure in the discharge hose before disconnecting the hose.

13. **LIGHT AND CHARGING SOCKET:** An optional marine grade light and charging socket is located on the top cover of the HP series portable pumps. This socket has a waterproof plug type cover that is removed to enable use of the optional light mast (Hale P/N 200-2100-02-0). The socket is also used to plug in the optional trickle charger (Hale P/N 200-0750-01-0) to maintain the charge on the pump's 12 volt battery.

14. **EXHAUST PRIMER ASSEMBLY:** The exhaust primer assembly is located on the outlet of the muffler. Located on the exhaust primer assembly is a 1/4 turn valve. Under normal operation conditions, when the pump is being operated from draft, the handle on the 1/4 turn valve will be in the open position (in-line with the tubing). When the pump is being

operated with a positive pressure source the valve must be closed to prevent water from being blown out of the exhaust pipe.

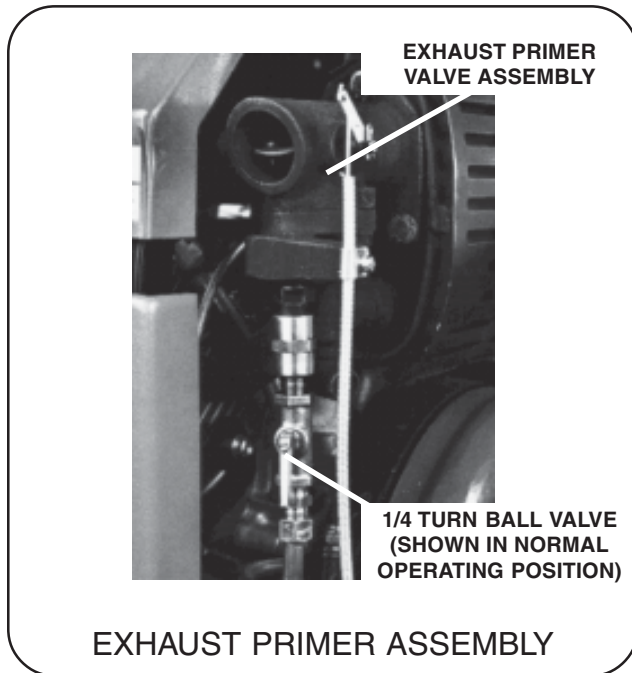

4 INITIAL CHECKOUT PROCEDURES

Upon receipt of the pump from the factory remove the pump and all accessories from the shipping container and check for damage. Note the serial number of the pump located on the engine air shroud near the recoil starter pull handle. Record this number on the warranty registration card located at the back of this manual and return warranty registration.

PORTABLE PUMP BATTERY ACTIVATION

After unpacking all pump components open the top cover on the pump and remove the battery from its holder. The battery is a dry charged battery and is shipped dry. Remove the covers from each cell of the battery and fill each cell with electrolyte. Replace the covers on each cell and tighten. Return the

battery to its holder and clamp in place.

CAUTION: Always connect the black wire to the negative battery terminal last.

Connect the red cable to the positive (+) terminal and connect the black cable to the negative (-) terminal. Make sure that the plastic overflow tube on the battery is directed down to the lowest point of the pump.

"X" SERIES PUMP INSTALLATION

1. After unpacking all pump components remove the mounting bolts and shock absorbing feet from the four corners of the pump. Retain these bolts and feet for securing the pump during installation.

2. To assist in pump mounting a mounting dimension drawing is included at the back of this manual. Mark location of the mounting holes in accordance with this drawing.

3. Drill 9.5 mm (3/8 inch) diameter holes at the four corners of the pump to insert the bolts to hold the pump in place. Place pump at proper location on the apparatus making sure the shock absorbing feet are under each corner.

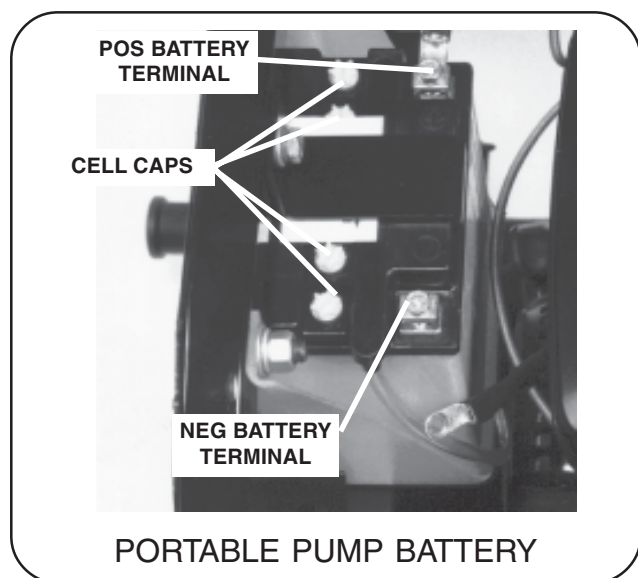

PORTABLE PUMP BATTERY

Insert the bolts and secure in place with lockwashers and nuts provided.

4. When the pump is mounted and if access is not provided to fill the fuel tank install optional fill tube and vent extension as required.

NOTE: The fuel tank on the HP series pump is already vented, therefore a vented fuel cap is not required

5. Locate and install the instrument panel on the apparatus. A dimensional drawing is provided of the instrument panel to locate the mounting holes. (NOTE: Approximately 2 meters (6 feet) of wire and control cables is provided with the pump. When locating the instrument panel the installer must take this into account.) Make electrical connection from the instrument panel to the pump with the jumper wires provided.

6. Connect throttle lever and choke control to the engine. Secure in place with the clamps provided. After the connections are made ensure the controls work smoothly. There may be excess cable after the connections are made. Make a loose coil of the cable and secure in place with wire ties.

CAUTION: The pump and motor assembly are vibration

isolated. When making the permanent connections to the suction and discharge fittings **DO NOT** use hard piping. A short length of flexible piping is required to prevent damage to the pump and engine.

7. Make piping connections to the discharge flange as required. When making the piping connections it may be necessary to turn the pump volute for proper alignment. To turn the pump volute:

- a. Loosen and remove the "V"-band clamp using a 1/2 inch or 13 mm deep well socket.
- b. Remove the volute from the pump body.
- c. Locate and remove the positioning roll pin from the pump body.
- d. Return the volute to the pump body and install "V"-band clamp.
- e. Turn the volute as necessary when

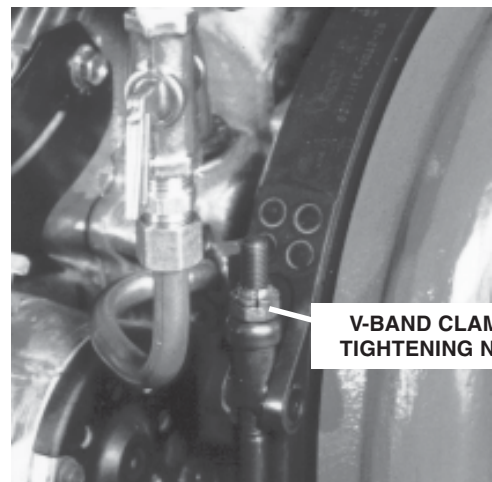

**HP SERIES
PORTABLE PUMPS**

USER OPERATION AND MAINTENANCE

making discharge piping connection.
f. After the discharge connection is complete tighten the "V"-band clamp to prevent leakage.

8. Connect the exhaust priming lever cable to the exhaust primer.

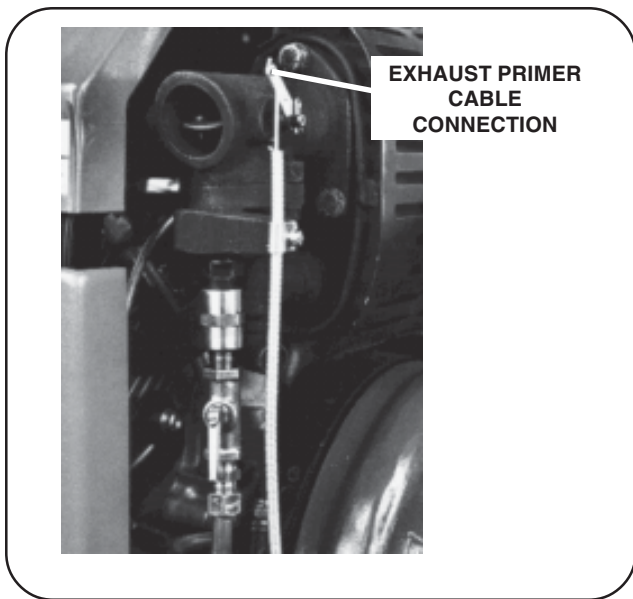

9. Connect tubing for the suction and discharge gauges. Use the 1/4 inch diameter tubing provided with the pump for gauge connections. If a longer length of tubing is required use 1/4 inch diameter tubing rated at the maximum operating pressure of the pump. Connections to the gauges and pump are compression type. Make sure the gauge lines are connected to the proper connection on the pump body.

10. Make piping connection to the

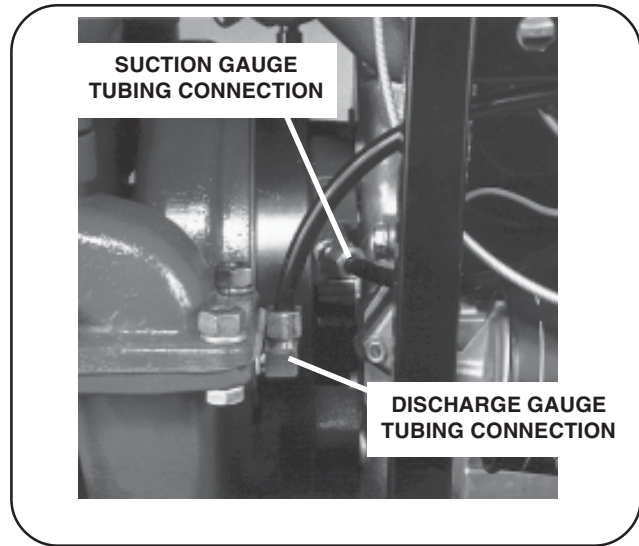

suction fitting as required. When making this connection ensure there are a minimum of restrictions such as elbows and couplings. Also, to protect the pump from debris a strainer shall be installed in the suction connection.

CAUTION: Always connect the black wire to the negative battery terminal last.

11. Connect the pump electrical system to a 12 volt battery to provide power to start the pump. Always connect the positive battery cable first.

NOTE: The pump may be connected to the apparatus battery or a separate battery may be used.

INITIAL OPERATION CHECKOUT

After activating the battery on the portable pump, or installing the "X" series pump, prior to placing the pump into

operation the following items must be checked.

WARNING: DO NOT smoke when filling fuel tank.

WARNING: DO NOT fill fuel tank while engine is running. Allow engine to cool for two minutes before refueling.

WARNING: DO NOT operate engine when an odor of gasoline is present or other explosive conditions exist

WARNING: DO NOT STORE, SPILL, OR USE GASOLINE NEAR AN OPEN FLAME, or devices such as a stove, furnace, or water heater which utilize a pilot light or devices which can create a spark.

WARNING: DO NOT refuel indoors where area is not well ventilated. Outdoor refueling is preferred.

1. **CHECK FUEL LEVEL:** Remove fuel filler cap to check fuel level. Fill tank as necessary and replace cap. **DO NOT** fill the fuel tank to the point of overflowing. The tank is designed to provide sufficient expansion space when the tank is full. When refilling the fuel tank ensure the pump is level to prevent overflowing or fuel being spilled on the ground.

FUEL RECOMMENDATIONS: Use clean, fresh, lead-free

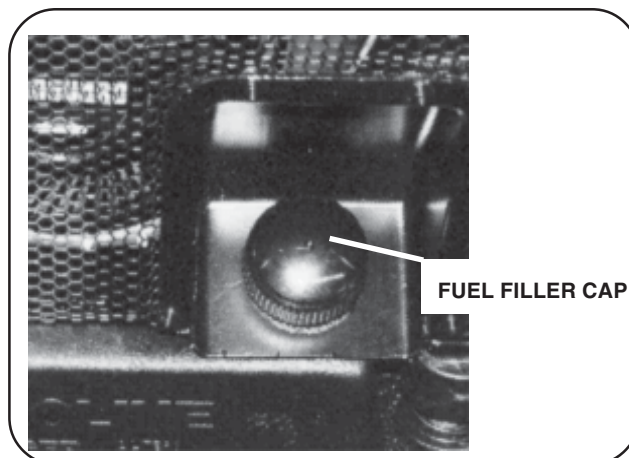

gasoline. The engine will operate satisfactorily on any gasoline intended for automotive use. A minimum of 85 octane is recommended. **DO NOT MIX OIL WITH GASOLINE.** Leaded gasoline may be used if lead-free is not available.

NOTE: The use of gasoline which contains alcohol, such as gasohol is not recommended. If gasoline with alcohol must be used, it **MUST NOT** contain more than 10 percent Methanol and **MUST** be removed from the engine during storage.

2. **PRIME FUEL SYSTEM:** When initially placing the pump into operation gain access to the fuel primer bulb, located behind the pump cover on the portable pump, and squeeze until firm. Replace cover after fuel system is primed.

CAUTION: The pump is shipped without oil in the

**HP SERIES
PORTABLE PUMPS**

USER OPERATION AND MAINTENANCE

engine crankcase. Before placing pump into operation for the first time fill engine crankcase to proper level with SAE 30 Weight Detergent oil.

3. FILL ENGINE WITH OIL: When received the engine crankcase does not contain oil. Remove oil dipstick or cap on valve cover and fill with 3.5 pints of SAE 30 Oil. Check oil level by removing the oil dipstick and wiping oil from dipstick with clean cloth. Screw dipstick firmly into place until cap bottoms on tube. Remove to check oil level. If necessary add additional oil to bring oil up to the proper level. Dipstick assembly must be firmly assembled into tube when engine is operating .

CAUTION: The HP100 is shipped without oil in the gearbox. Before placing

pump into operation for the first time fill gearbox to proper level with SAE 30 Weight Detergent oil.

4. FILL HP100 GEAR BOX WITH OIL: The HP100 is shipped without oil in the gear box. Add oil to proper level in accordance with procedures listed in section 8. Replace oil level plug.

5. CONNECT SUCTION HOSE: Ensure the hose connections are tightened with a spanner and a strainer is placed at the end of the hose to prevent debris from entering the pump and causing irreparable damage. Place end of suction hose in water source. Make sure the end of the suction hose does not become submerged in the mud or silt on the bottom. Also make sure the suction hose has no bends or loops that are higher than the suction connection of the pump that would trap air and prevent priming of the pump.

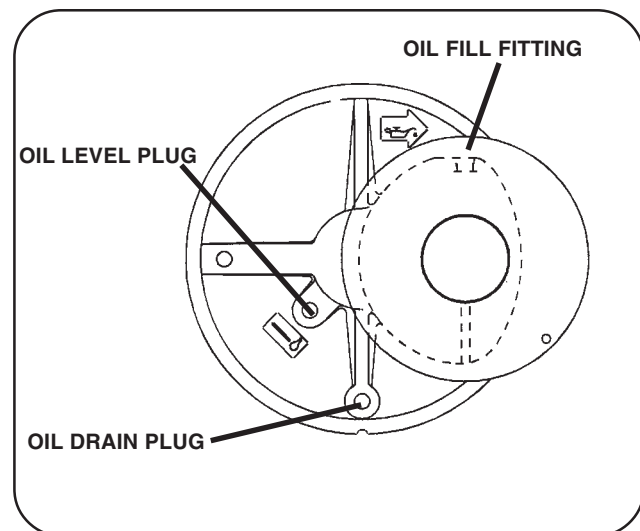
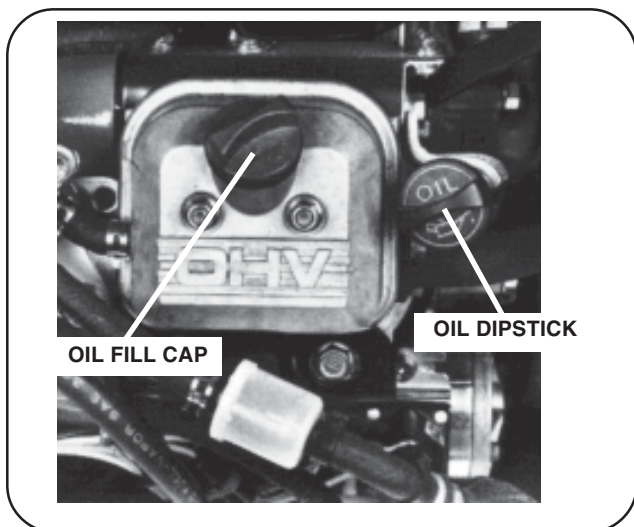

6. CONNECT DISCHARGE HOSE: After connecting discharge hose ensure the discharge valve is closed. Remove all kinks and sharp bends from the discharge hose.

7. CLOSE PUMP DRAINS: Make sure the pump and discharge valve drains are closed.

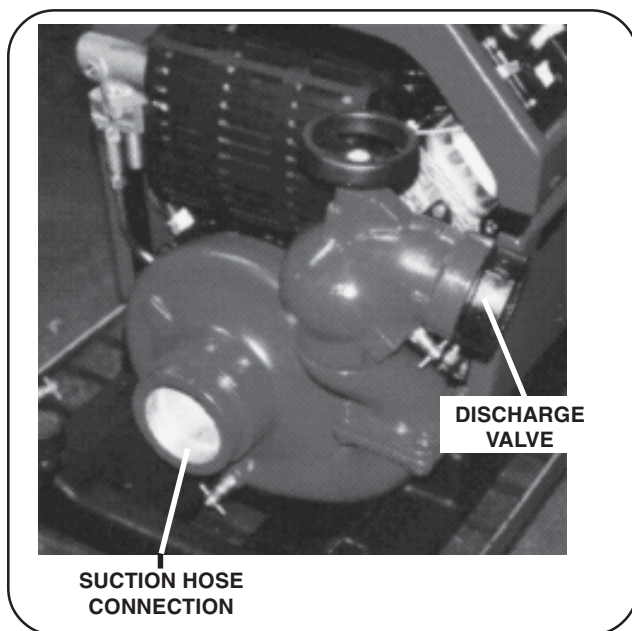

5 STARTING PROCEDURES

The following procedures will be followed to start the pump and establish water flow.

WARNING: DO NOT run engine in an enclosed area. Exhaust gases contain carbon monoxide, an odorless and deadly poison.

WARNING: Engine produces excessive noise. When pump is operating persons in the immediate vicinity must wear hearing protection.

1. **CLOSE VALVES:** Make sure all pump drains and discharge valves are closed

2. **SET THROTTLE LEVER:** Move throttle lever upward to fast () position.

3. **CHOKER ENGINE:** Pull choke knob () out fully to close choke on carburetor.

NOTE: A warm engine requires less choking than a cold engine. When starting a warm engine little or no choke will be required.

4. **ENERGIZE ELECTRICAL SYSTEM:** Place Master Switch to the ON (—) position. Check to make sure oil light is lit. This

indicates the battery is good and the pump is ready to start. If the oil light is not lit check the battery connections and ground connections. It may be necessary to start the pump using the recoil starter if the oil light does not light.

5. **START ENGINE:** Depress start push button () and hold until engine starts. When engine starts, open choke gradually by pressing in on choke knob.

NOTE: The best starter life is provided by using short starting cycles of several seconds. Prolonged cranking (more than 15 seconds per minute) can damage the starter motor. If the engine does not start in 15 seconds release starter button. Allow starter to cool two minutes.

If the engine does not start using the electric starter, the recoil starter must be used.

- a. Open pump cover on instrument panel side of the pump if applicable.
- b. Locate recoil starter handle and pull slowly until resistance is felt then pull rapidly to overcome compression, prevent kickback and start engine.
- c. Once the engine starts open choke gradually by pressing in on choke knob.

For the "I" version, turn the key switch and release when the pump has started.

6. **PRIME PUMP:** Hold priming lever  down to prime the pump and establish suction. Monitor suction and discharge gauges to determine when suction is established. Once suction is established release the priming lever and make sure the lever returns to the up position.

CAUTION: Do not run pump for more than 45 seconds without suction established.

NOTE: When the pump is connected to a positive pressure source priming is not required. When using the pump with a positive pressure connected to the inlet ensure the 1/4 turn valve on the exhaust primer assembly is in the closed position prior to starting the pump.

7. **ESTABLISH DISCHARGE:** Once suction is established as indicated by the gauges, open the pump discharge valve by rotating handle counterclockwise.

8. **ADJUST THROTTLE:** Adjust throttle lever

to obtain the desired discharge pressure on the discharge gauge.

CAUTION: Exhaust system components may smoke during the initial break-in period. This smoking will stop after the pump is run several times.

COLDWEATHER STARTING HINTS

1. Be sure to use the proper oil for the temperature expected.
2. Set speed control at part-throttle position.
3. A warm battery has much more starting capacity than a cold battery.
4. Use fresh winter grade fuel.

NOTE: Winter grade gasoline

6 SHUTDOWN AND STORAGE PROCEDURES

To enhance pump life the following procedures shall be used when shutting down the pump.

1. **SLOW ENGINE:** Move throttle lever to the slow () position.

2. **SECURE DISCHARGE:** Close pump discharge valve by rotating handle clockwise.

3. **SECURE ELECTRICAL POWER:** Turn master switch to the off (⦿) position.

NOTE: Do not choke carburetor to stop the engine. Fire may result if choke is used to stop engine.

Prior to placing the pump in storage after each use the following must be accomplished. This procedure is extremely important if the pump has been run in salt water or freezing conditions will be encountered.

1. **MAKE HOSE CONNECTIONS:** Connect suction hose and place end in a **CLEAN WATER** source. Then connect discharge hose and prepare to operate pump.

2. **ENERGIZE PUMP:** Start engine and establish water flow through pump.

3. **FLUSH PUMP:** Run pump for 2 minutes to ensure clean water has circulated through the pump.

4. **DE-ENERGIZE PUMP:** After water has circulated through the pump for 2 minutes turn the master switch to the off position.

5. **UNDO HOSE CONNECTIONS:** Disconnect suction hose and discharge hose. Drain hoses and place in proper storage area

6. **DRAIN PUMP:** Open drain valves and allow all water to drain from the pump body.

7. **CLOSE VALVES:** Once all water is drained from the pump close the discharge valve and drain valve.

8. **CHECK FLUID LEVELS:** Check oil level and fuel level and refill as necessary.

9. **CLEAN PUMP:** Clean any debris from the outside of the engine and pump.

Also, wipe the pump covers down with a clean damp cloth. If necessary use a mild soap and water solution to clean plastic covers.

10. **STORE PUMP:** Return pump to storage compartment and secure in place.

7 MAINTENANCE SCHEDULE

MAINTENANCE INTERVALS

To prolong pump life and ensure reliable operation the pump user shall perform the maintenance described in the following section on a regular basis. The table that follows provides a listing of the minimum maintenance intervals. Following the chart are detailed maintenance procedures.

MAINTENANCE OPERATION	Every 8 Hours or Daily	25 Hours or Weekly	50 Hours or Monthly	100 Hours or Yearly	Yearly
ENGINE MAINTENANCE					
Check Oil Level	●				
Change Oil † (NOTE 1)			●		
Change Oil Filter				●	
Clean Foam Air Cleaner Pre-Cleaner (NOTE 2)		●			
Service Air Cleaner Cartridge (NOTE 2)				●	
Clean Cooling System (NOTE 2)				●	
Clean Debris Gard (NOTE 2)	●				
Inspect Spark Arrester				●	
Replace In-Line Fuel Filter					●
Replace Spark Plug				●	
Check Valve Clearance					●
PUMP MAINTENANCE					
Check Oil Level (NOTE 3)	●				
Change Gear Oil (NOTE 3)			●		
Leak Test					●
† : Change oil after first 8 hours.					
NOTE 1: Change oil every 25 hours when operating under heavy load or in high ambient temperature.					
NOTE 2: Clean more often under dusty conditions or when airborne debris is present.					
NOTE 3: HP100 Model Pump Only.					

8 PUMP MAINTENANCE

The HP Series portable pumps are designed to provide years of reliable service with a minimum of maintenance on the pump end. The pump must be cleaned and flushed out after each use. Failure to clean and flush the pump may degrade pump performance. The only maintenance that is usually required on a regular basis is to hydrostatically test the pump each year.

LEAKTEST

A leak test of the pump must be performed each year. The leak test will be conducted at the pump working pressure.

WARNING: TO PREVENT ACCIDENTAL STARTING when servicing the engine or pump always disconnect the negative wire from battery terminal.

CHECK OIL LEVEL (HP100 GEARBOX)

The HP100 pump has a gearbox that requires routine maintenance. The oil should be checked in the gearbox every eight hours of operation and after each use of the pump. The following procedures are used to check the oil level in the HP100 gearbox.

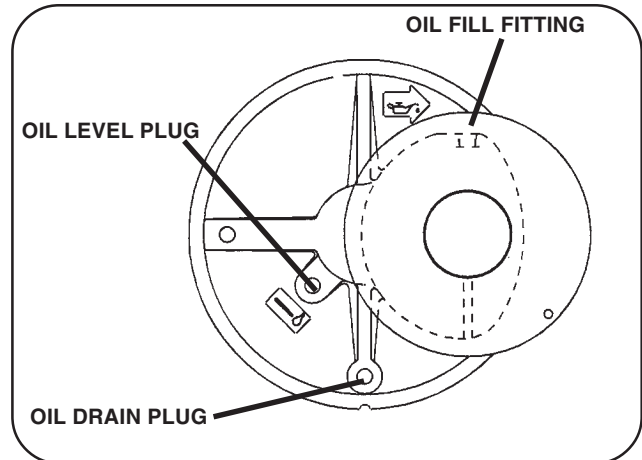

1. Place pump on a level work surface to gain access to the gearbox.
2. Locate the oil fill fitting, the oil level plug and the oil drain plug on the pump gearbox.
3. Loosen oil level plug with wrench and begin to remove slowly. If the oil is at the proper level there should be a slight trickle of oil from around the plug.
4. Replace plug and tighten. If oil needs refilling remove oil fill fitting, vent and oil level plug. Add new gear oil (SAE 30) through oil fill fitting until oil starts to flow from oil level plug. Replace and tighten oil level plug.

HP SERIES PORTABLE PUMPS

USER OPERATION AND MAINTENANCE

5. Replace oil fill fitting and vent.
6. Return pump to storage or operation.

CHANGE GEARBOX OIL (HP100)

The oil in the gearbox of the HP100 should be changed after every 50 hours of operation. The following procedures shall be used to change the gearbox oil.

1. Place pump on clean level work surface and gain access to the pump gearbox.
2. Place container under oil drain plug to catch waste oil.
3. Using a wrench remove oil drain plug.

NOTE: The oil may not flow freely from the gear case at first. To facilitate oil flow remove oil fill fitting.

4. Replace oil drain plug after all oil has drained from the gearbox.

NOTE: Dispose of waste oil in accordance with local ordinances.

5. Obtain proper grade of oil (SAE 30).

6. Remove oil level plug from gearbox.

7. Place funnel in oil fill fitting and slowly pour oil into gearbox until oil starts to flow from the oil level hole.

8. Replace oil level plug, oil fill fitting and vent.

9. Return pump to storage or operation.

EXHAUST PRIMER MAINTENANCE

The exhaust primer should be cleaned after every 100 hours of operation or when priming of the pump appears sluggish. The following procedures shall be used to clean the exhaust primer.

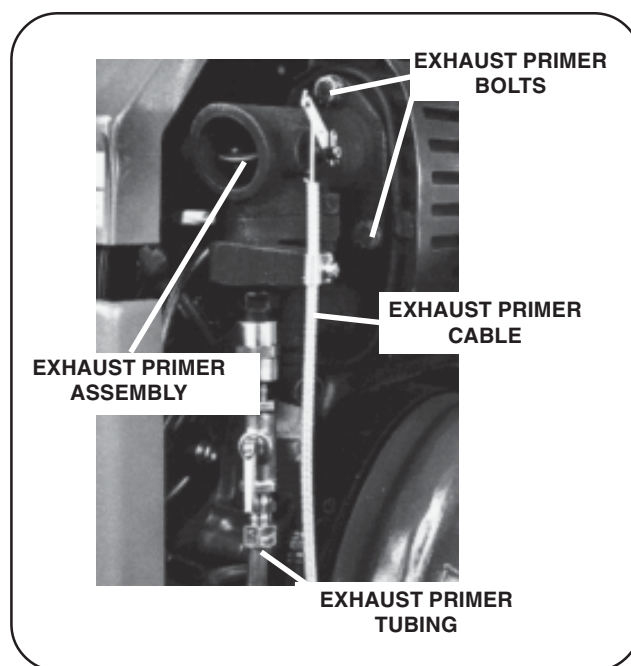

WARNING: TO PREVENT ACCIDENTAL STARTING when servicing the engine or pump always disconnect the negative wire from battery terminal.

1. Place pump on clean work surface and gain access to the exhaust primer.
2. Disconnect Negative battery terminal to prevent accidental starting of the pump.
3. Unsnap and remove the muffler heat shield.
4. Disconnect cable from the actuating lever to the butterfly. Disconnect all tubing from the exhaust primer.
5. Remove hex head screws that hold the exhaust valve to the muffler. Remove the exhaust valve to a clean work surface.
6. Place exhaust valve assembly on bench with ejector body facing up. Remove hex head screws and separate the ejector body from the exhaust valve body.
7. Remove check valve ball from ejector body.
8. Using wire brush and tip cleaners carefully remove carbon from ejector nozzle and check valve assembly.
9. Insert check valve ball into ejector body. Using a new gasket (P/N 046-0850-01-0) assemble ejector body to exhaust valve body using hex head screws.
10. Install exhaust valve assembly to the muffler using new gasket (P/N 046-6240-01-0) and hex head screws.
11. Connect hoses and cables that were disconnected back to the exhaust valve assembly.
12. Ensure priming lever on instrument panel moves freely after assembly. If lever does not move freely the conduit or cable may be dirty or damaged. Clean or replace as necessary.
13. Replace the heat shield on the muffler and snap in place.
14. Reconnect the negative battery terminal.
15. Return pump to ready condition.

9 ENGINE MAINTENANCE

General Information

This is a twin cylinder, overhead valve, air cooled engine. All drilled/tapped holes and fasteners on this engine are ISO metric. However, where equipment attaches to engine, SAE standards apply.

WARNING: TO PREVENT ACCIDENTAL STARTING when servicing the engine or pump always disconnect the negative wire from battery terminal.

CHECK OIL LEVEL

The oil level should be checked after each 8 hours of operation. Use the following procedure to check the oil level:

1. Place pump on level surface.
2. On portable pump, undo latches and open top cover to gain access to dipstick.
3. Unscrew oil dipstick cap, remove oil dipstick and wipe oil from dipstick.
4. Screw dipstick firmly into place until cap bottoms on tube.
5. Unscrew oil dipstick cap, remove oil dipstick and check oil level. Proper oil level is when oil is visible on the dipstick end between the "ADD" and "FULL" marks.
6. Screw dipstick firmly into place until cap bottoms on tube. Cap must be tight while pump is operating.

7. Close pump cover and latch in place.

CHANGE OIL

Change oil after the first 8 hours of operation. Then, under normal operating conditions, change oil every 50 hours of operation or monthly, whichever occurs first.

NOTE: Oil should be changed every 25 hours of operation if the engine is operated under heavy load, or in high ambient temperatures.

When changing oil use a high quality SAE 10W-30 or SAE 30 weight detergent oil classified "For Service SC, SD, SE, SF or SG". Detergent oils keep the engine cleaner and retard the formation of gum and varnish deposits. No special additives should be used with recommended oils. The following table provides the recommended viscosities of oil to use based on the anticipated operating temperature range.

RECOMMENDED SAE VISCOSITY GRADES

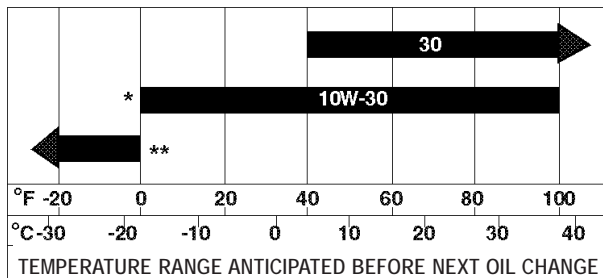

* 10W-40 oil may be used if 10W-30 is not available.

** Use synthetic oil having 5W-20, 5W-30 or 5W-40 viscosity. If not available, a petroleum based oil may be used having 5W-20 or 5W-30 viscosity.

Change oil using the following procedures:

1. Place the pump assembly in a work area where access can be made to the oil drain fitting. Ensure the pump is level. Disconnect Negative battery cable to prevent accidental starting of the pump.
2. Place container under oil drain fitting to catch waste oil as it drains from the pump.

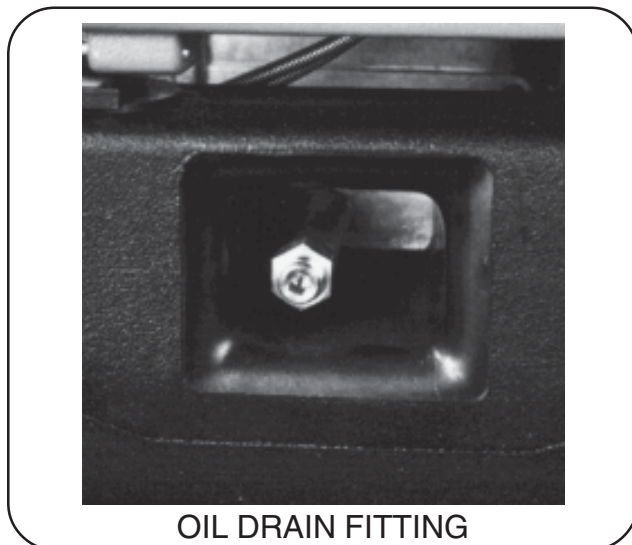

OIL DRAIN FITTING

3. The oil drain fitting is a hex fitting with a pipe plug. Use adjustable wrench to hold hex fitting while removing the pipe plug with an allen wrench.

4. Once all oil is drained from the crankcase replace pipe plug in oil drain fitting and tighten with allen wrench.

NOTE: Dispose of waste oil in accordance with local ordinances.

5. Remove oil fill cap on valve cover or dipstick and place on a clean surface.

6. Using a funnel to prevent spills, refill crankcase with the proper grade of oil.

NOTE: The engine will require a minimum of 3 pints (1.4 liters) if the oil filter is not replaced and 3.5 pints (1.6 liters) if the oil filter is replaced.

7. Check oil level and replace dipstick or oil fill cap.

8. Reconnect negative battery cable. Start pump and run for 30 seconds. Shut down the pump and

HP SERIES PORTABLE PUMPS

USER OPERATION AND MAINTENANCE

check oil level. Refill crankcase as necessary.

9. Check area around pump for oil leaks.
10. Return pump to storage area.

REPLACE OIL FILTER

The oil filter should be replaced after every 100 hours of pump usage or yearly.

WARNING: TO PREVENT ACCIDENTAL STARTING when servicing the engine or pump always disconnect the negative wire from battery terminal.

NOTE: The engine oil should be changed whenever the oil filter is replaced.

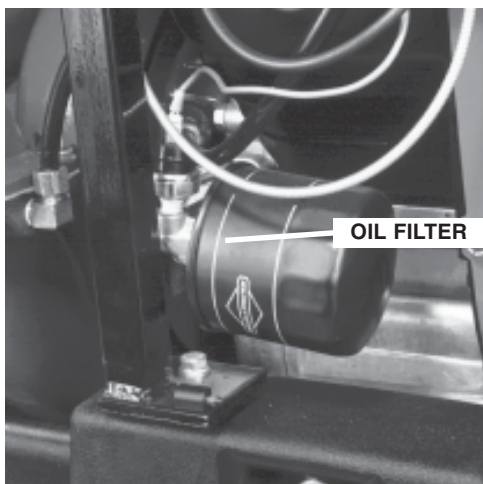

OIL FILTER ASSEMBLY

Replace the oil filter using the following procedures:

1. Place the pump assembly in a work area where access can be made to the oil drain fitting. Ensure the pump is level.
2. On portable pump unlatch and remove covers to gain access to engine. Disconnect the negative battery cable to prevent accidental starting.
3. Place container under oil drain fitting to catch waste oil as it drains from the pump.
4. The oil drain fitting is a hex fitting with a pipe plug. Use adjustable wrench to hold hex fitting while removing the pipe plug with an allen wrench.
5. Once all oil is drained from the crankcase replace pipe plug in oil drain fitting and tighten with allen wrench.

NOTE: Dispose of waste oil in accordance with local ordinances.

6. Using oil filter wrench remove and dispose of old oil filter.

NOTE: Before installing new filter, lightly oil filter gasket with fresh clean engine oil.

7. Oil the filter gasket and screw the new oil filter on by hand until gasket contacts filter adapter then tighten an additional 1/4 to 1/2 turn.

8. Remove oil fill cap on valve cover or oil dipstick and place on a clean surface.

9. Using a funnel to prevent spills, refill crankcase with the proper grade of oil.

NOTE: The engine will require a minimum of 3 pints (1.4 liters) if the oil filter is not replaced and 3.5 pints (1.6 liters) if the oil filter is replaced.

10. Check oil level and replace dipstick or oil fill cap.

11. Replace covers and remove pump from work area.

12. Reconnect the negative battery cable. Start pump and run for 30 seconds. Shut down the pump and check oil level. Refill crankcase as necessary.

13. Check area around pump for oil leaks.

14. Return pump to storage area.

DUAL ELEMENT AIR CLEANER

The air cleaner consists of a foam pre-cleaner and a paper cartridge. The foam pre-cleaner should be serviced after every 25 hours of pump operation or weekly. The paper cartridge should be serviced after every 100 hours of pump operation or yearly.

WARNING: TO PREVENT ACCIDENTAL STARTING when servicing the engine or pump always disconnect the negative wire from battery terminal.

NOTE: Service air cleaner more often when operating under dusty conditions.

1. On the portable pump, unlatch and open the pump top cover to gain access to the air cleaner. Disconnect negative battery cable.

2. Remove air cleaner cover assembly by releasing the latches on either side of the cover and lift cover off pump.

**HP SERIES
PORTABLE PUMPS**

USER OPERATION AND MAINTENANCE

3. Remove nut holding retainer plate, cartridge and foam pre-cleaner to top of engine.
4. Remove retainer plate and foam pre-cleaner from cartridge.
5. Service foam pre-cleaner:
 - a. Wash in liquid detergent and water.
 - b. Squeeze dry in a clean cloth.
 - c. Saturate in engine oil. Squeeze in clean, absorbent cloth to remove all excess oil.
6. Service cartridge:
 - a. Clean by tapping gently on flat surface.
 - b. If very dirty, replace, or wash in a low or non-sudsing detergent and warm water solution. Rinse thoroughly with flowing water from mesh side until water runs clear. Let

cartridge air dry thoroughly before using.

CAUTION: Petroleum solvents, such as kerosene, are not to be used to clean cartridge. They may cause deterioration of the cartridge. **DO NOT OIL CARTRIDGE. DO NOT USE PRESSURIZED AIR TO CLEAN OR DRY CARTRIDGE**

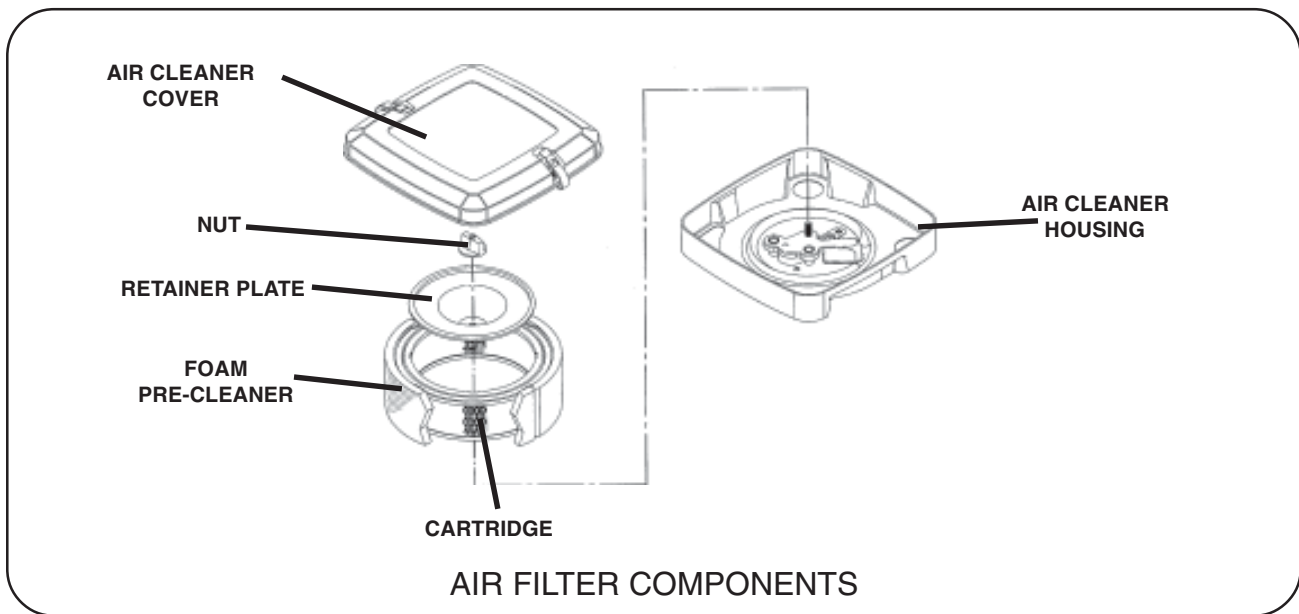
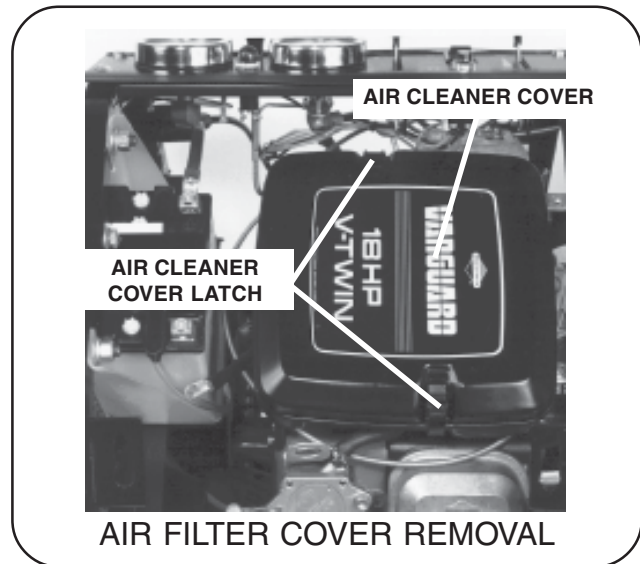

7. Reinstall pre-cleaner and retainer ring on cartridge.

8. Reinstall foam pre-cleaner, cartridge and retainer plate assembly in air cleaner housing on top of engine. Secure in place with nut.

9. Reinstall air cleaner cover on top of pump and latch in place.

WARNING: DO NOT run engine with air cleaner or air cleaner cover removed.

10. Reconnect negative battery cable and close pump cover as necessary.

CLEAN COOLING SYSTEM

If the pump is operated in an area where there is loose debris such as grass, papers, leaves or dirt the rotating screen and the air cooling system may become clogged after prolonged service. After every 100 hours of operation or yearly remove the pump covers and blower housing and clean the areas shown in the illustration to prevent engine damage caused by overheating and/or over-speeding. Clean more often if necessary.

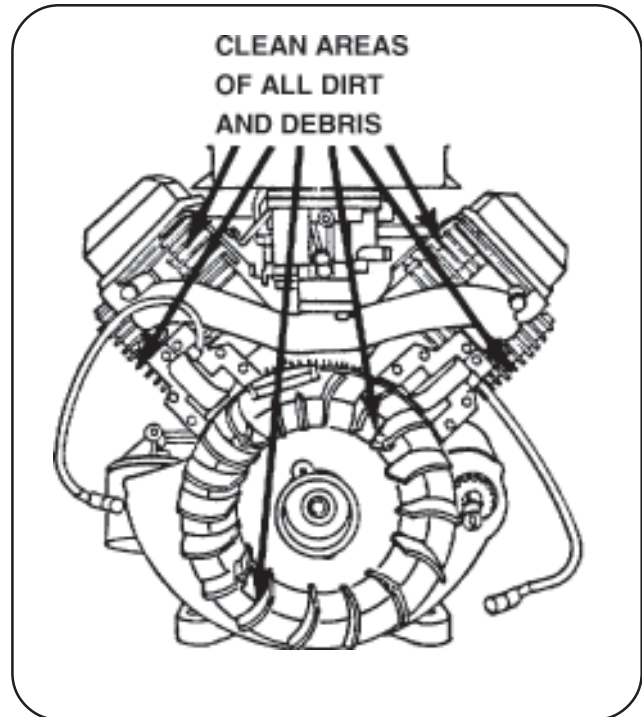

CLEAN DEBRIS GUARD

If the pump is operated in a dry area where there is loose debris such as grass, papers, leaves or dirt this debris must be removed from the debris guard daily or more often if needed to prevent engine damage caused by overheating and/or over-speeding.

CAUTION: For proper engine operation, keep controls and linkages clean and free of debris.

CAUTION: Periodically clean muffler area to remove all grass, paper, leaves, dirt or other combustible debris.

CLEAN SPARK ARRESTER SCREEN

The engine muffler is equipped with a spark arrester screen assembly. Remove

**HP SERIES
PORTABLE PUMPS**

USER OPERATION AND MAINTENANCE

this assembly every 50 hours of pump operation or monthly for cleaning and inspection.

WARNING: TO PREVENT ACCIDENTAL STARTING when servicing the engine or pump always disconnect the negative wire from battery terminal.

To remove the spark arrestor screen make sure the pump and muffler are cool and proceed as follows:

1. Remove heat shield from muffler assembly and locate the exhaust primer assembly.
2. Disconnect negative battery cable to prevent accidental starting of the pump.

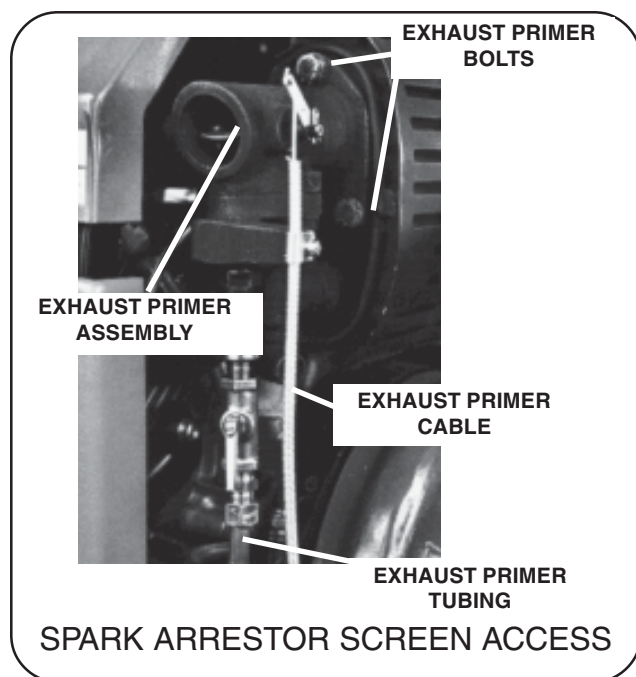

3. Disconnect primer tubing and primer control cable as necessary.
4. Remove the three bolts that hold the exhaust primer assembly on the muffler. Remove the exhaust primer assembly.
5. Remove the spark arrestor screen assembly from the muffler.
6. Clean the spark arrestor screen assembly with a stiff wire brush.
7. Inspect spark arrestor screen assembly for damage and deterioration. If the screen is damaged replace the screen.
8. Install new gasket along with the Spark arrestor screen assembly on the muffler.
9. Install another new gasket and the exhaust valve primer assembly. Secure with the three bolts.
10. Connect exhaust primer control cable and primer tubing as required.
11. Install the heat shield on the muffler.
12. Connect negative lead to battery.

13. Return pump to storage or operation.

Spark Plug Type	Champion	Autolite
Resistor	RC12YC	3924
Spark Plug Gap	76 mm (.030 in.)	

REPLACE SPARKPLUGS

Replace the spark plugs every 100 hours of operation or yearly.

To replace the spark plugs ensure the pump is cool and proceed as follows:

1. Unlatch and remove pump engine covers to gain access to the pump engine.
2. Disconnect negative battery lead.
3. Remove spark plug wire from spark plug.
4. Using spark plug wrench remove spark plug.

NOTE: Do not blast clean spark plug. Spark plug should be cleaned by scraping or wire brushing and washing with a commercial solvent.

NOTE: In some areas, local law requires the use of a resistor spark plug to suppress ignition signals. If the engine was originally equipped with a resistor spark plug, be sure to use the same type of spark plug for replacement. The following is a list of the recommended sparkplugs.

5. Obtain new spark plug and check gap using a wire gauge. The proper gap is 0.030 in (0.76 mm).

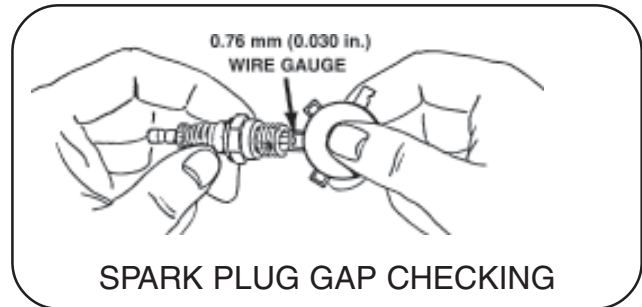

6. Insert the new spark plug into hole and screw in being careful not to cross thread.

7. Reconnect spark plug wire to spark plug.

CAUTION: Sparking can occur if wire terminal does not fit firmly on spark plug. Reform terminal if necessary.

8. Reconnect negative battery lead.

9. Install pump covers and latch in place.

REPLACE FUEL FILTER

A clogged or dirty fuel filter can adversely affect engine performance. The fuel filter should be replaced each year or more often as engine performance dictates. The following procedures are to be used to replace the fuel filter.

WARNING: TO PREVENT ACCIDENTAL STARTING when servicing the engine or pump always disconnect the negative wire from battery terminal.

1. Unlatch and open (or remove) pump covers on portable pump to gain access to the fuel filter. Disconnect negative battery cable.
2. Locate fuel filter.

3. Using pliers remove clips holding the fuel filter in the fuel line.
4. Place a container under the fuel filter to catch any excess fuel that may be in the lines.
5. Remove the fuel filter from the fuel lines.
6. Place new clips on the fuel lines.
7. Insert the new fuel filter in the fuel line and push fuel hoses onto connectors.
8. Using pliers, slide clips towards the fuel filter to clamp hoses in place.
9. Close (or replace) pump covers on portable pump and latch.

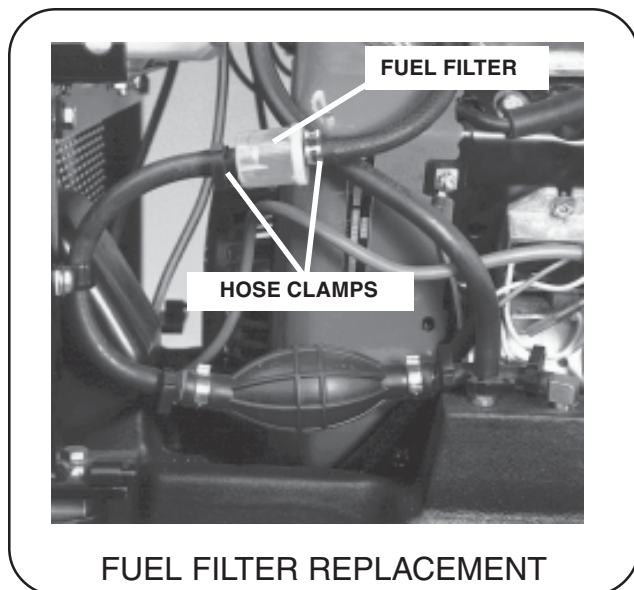

PORTABLE PUMP BATTERY CHECK

To ensure reliable operation of the pump the battery must be checked annually to ensure sufficient power is available to start the engine. To accomplish the battery check the following procedures shall be used.

1. Open covers to pump, where applicable, and locate the battery.
2. Disconnect the cables from the positive and negative terminals.

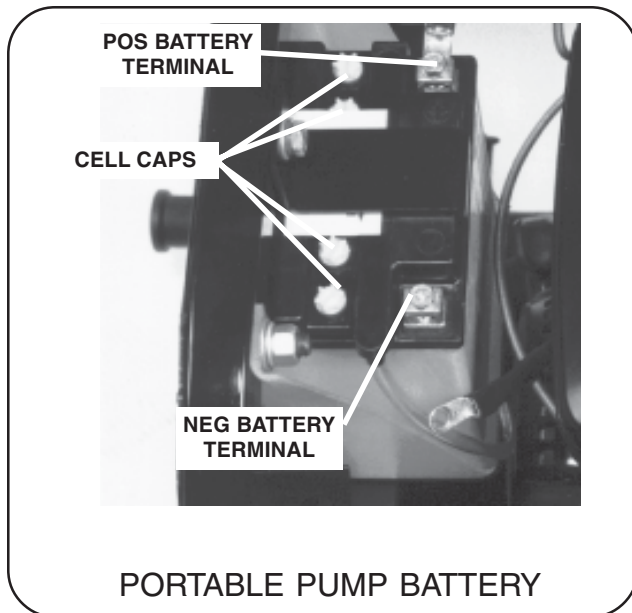

Always remove the negative terminal first.

3. Check the specific gravity of each cell with a hydrometer. All cells should have a specific gravity of 1.250 with no more than 0.50 variation between any two cells. If the specific gravity is less than 1.225 or varies by more than 0.50 between any two cells replace the battery.

4. Connect battery load test instrument to the terminals and place battery under simulated starting load with the test instrument. The meter should read 9 volts or more when the simulated starting load is applied. If the meter does not read 9 volts, replace the battery.

NOTE: Dispose of used battery in accordance with local ordinances.

5. Reconnect the cables to the positive and negative terminals. Always connect the negative terminal last.

6. Replace pump covers as necessary.

7. Return pump to storage area for operation.

10 WARRANTY POLICY

Hale Products, Inc., herein referred to as “Hale”, warrants products of its manufacture to be free from defects in material and workmanship, under normal use and service, for a period of two years or 2000 hours of usage, whichever comes first. Products used for rental or contracting purposes are warranted for a period of six months or 2000 hours of usage, whichever comes first. This limited warranty is effective only if the equipment or apparatus is used as directed, is not subjected to misuse, negligence or accident, and is not altered, treated or repaired by someone other than Hale or its designee. Items not manufactured by Hale shall bear only the limited warranties offered by their respective manufacturers.

The exclusive remedy for breach of this warranty shall be to give Hale written notice thereof and to request a Returned Goods Authorization. Upon receipt of the Returned Goods Authorization, the buyer will return the non-conforming material to Hale F.O.B. its plant within thirty days after the buyer has received the Returned Goods Authorization. Thereupon Hale at its own election shall repair or replace the same or repay the price thereof. No proximate, incidental, consequential or other damages shall be recoverable.

Hale shall not be liable for consequential damages or contingent liabilities including; but not limited to, loss of life, personal injury, loss of crops, loss due to fire or water property damage, and consequential trade or other commercial loss arising out of the failure of Manufacturer’s product.

HALE MAKES NO WARRANTIES OF FREEDOM FROM PATENT INFRINGEMENT, OF MERCHANTABILITY, OF FITNESS FOR A PARTICULAR PURPOSE OR ARISING FROM A COURSE OF DEALING OR USAGE OF TRADE OR OTHER LIKE OR DIFFERENT EXPRESS OR IMPLIED WARRANTIES EXCEPT AS MADE ABOVE.

11 MOUNTING DIMENSIONS

"X" SERIES PUMP MOUNTING DRAWINGS

The following pages contain drawings to assist in the mounting of "X" Series pumps on apparatus. The drawings are not to scale but will assist the installer in locating mounting holes for the pumps.

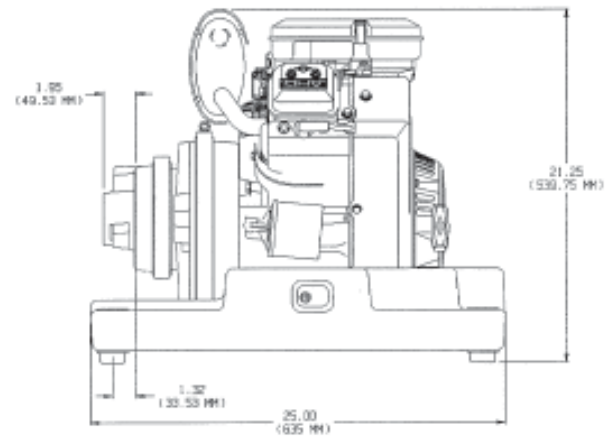
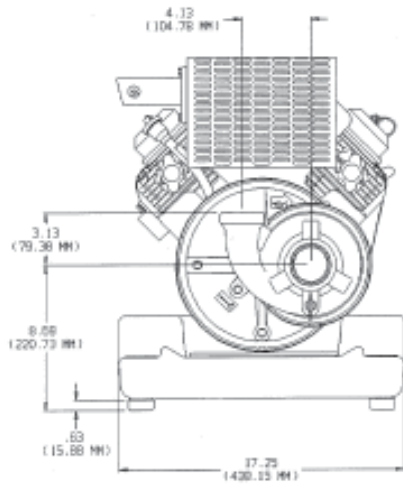

100X

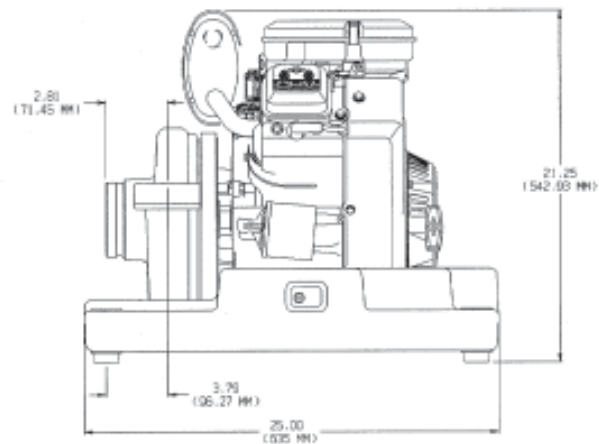
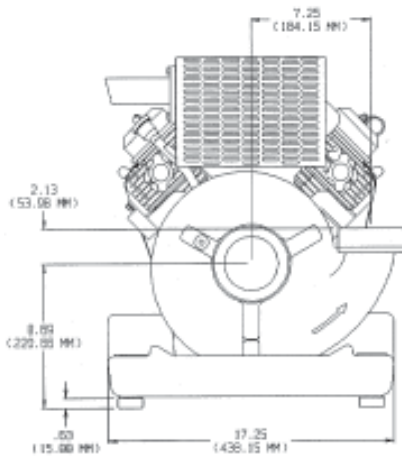

200X

"X" Series Pump Mounting Dimensions

**HP SERIES
PORTABLE PUMPS**

USER OPERATION AND MAINTENANCE

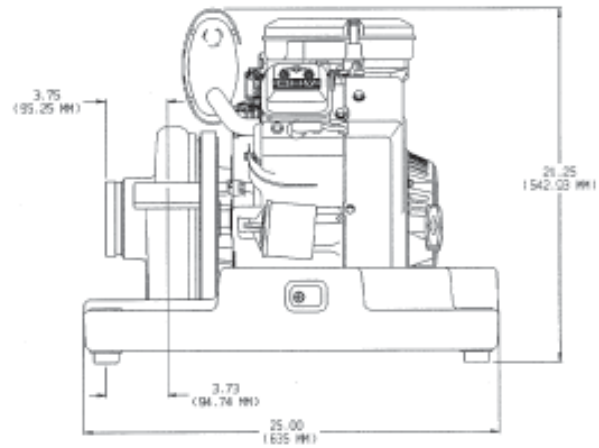
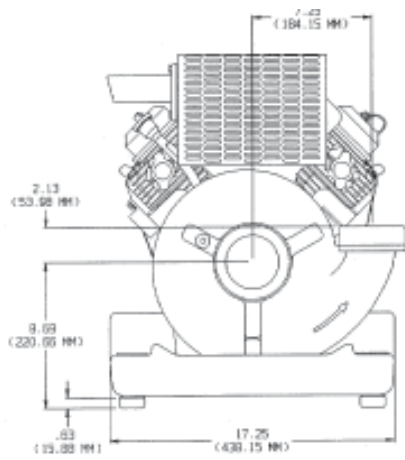

300X

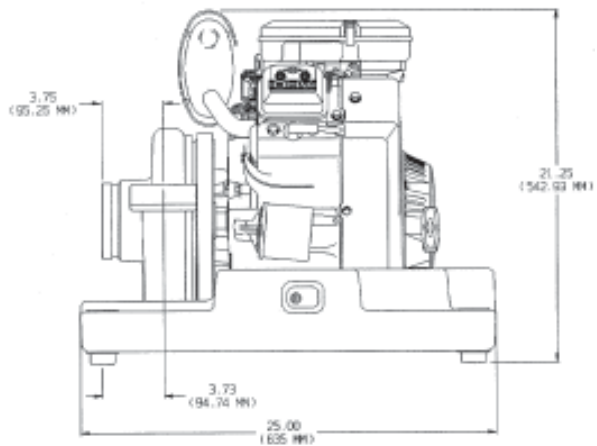
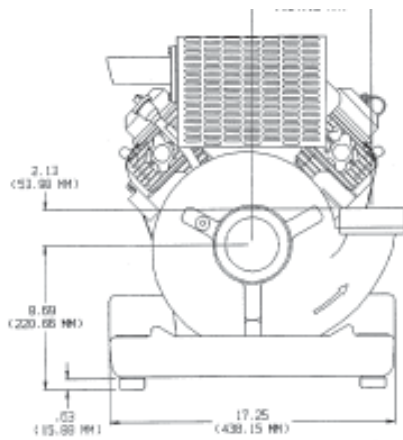

400X

"X" Series Pump Mounting Dimensions

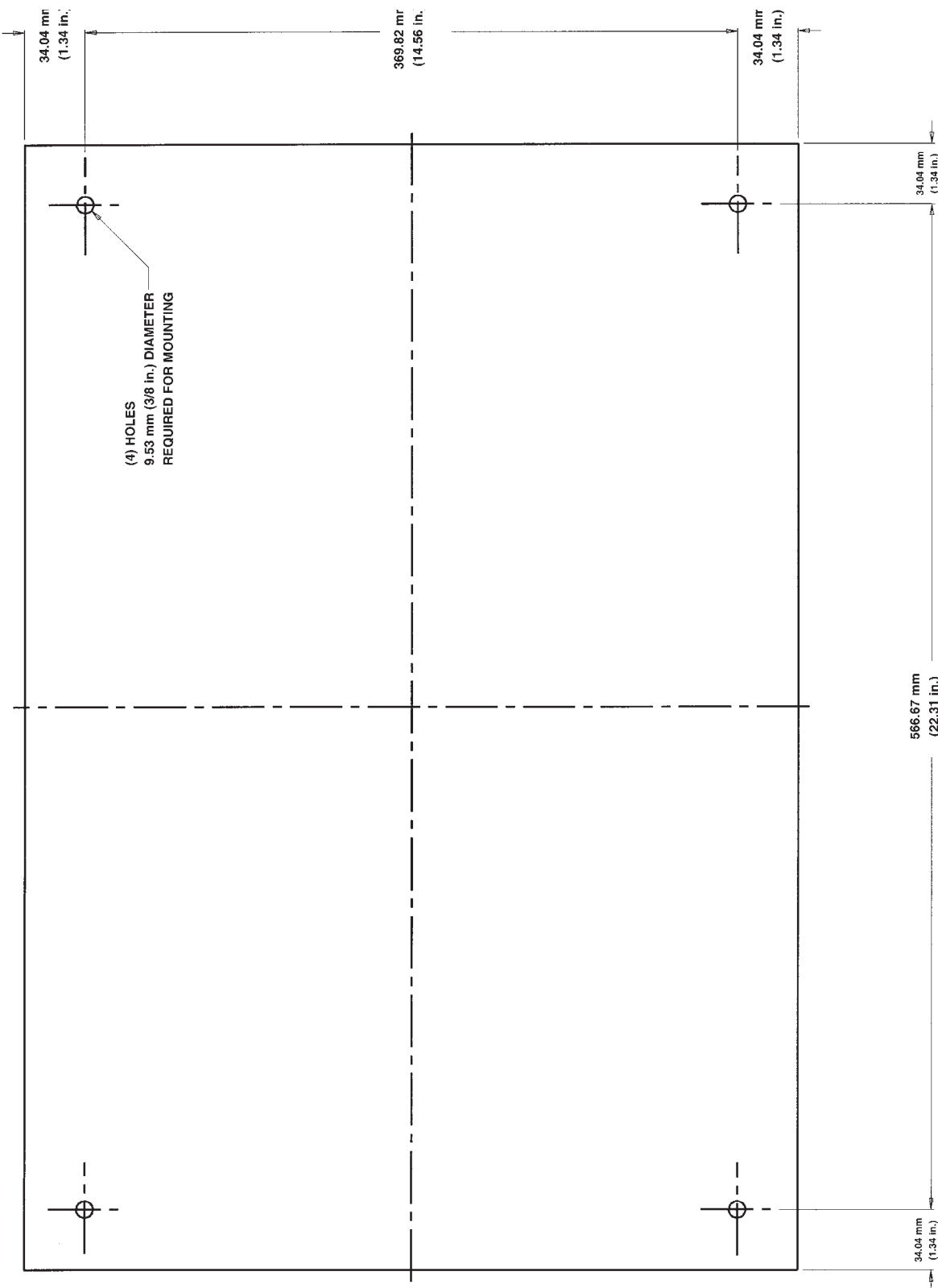

"X" Series Pump Base Mounting Hole Location Dimensions

**HP SERIES
PORTABLE PUMPS**

USER OPERATION AND MAINTENANCE

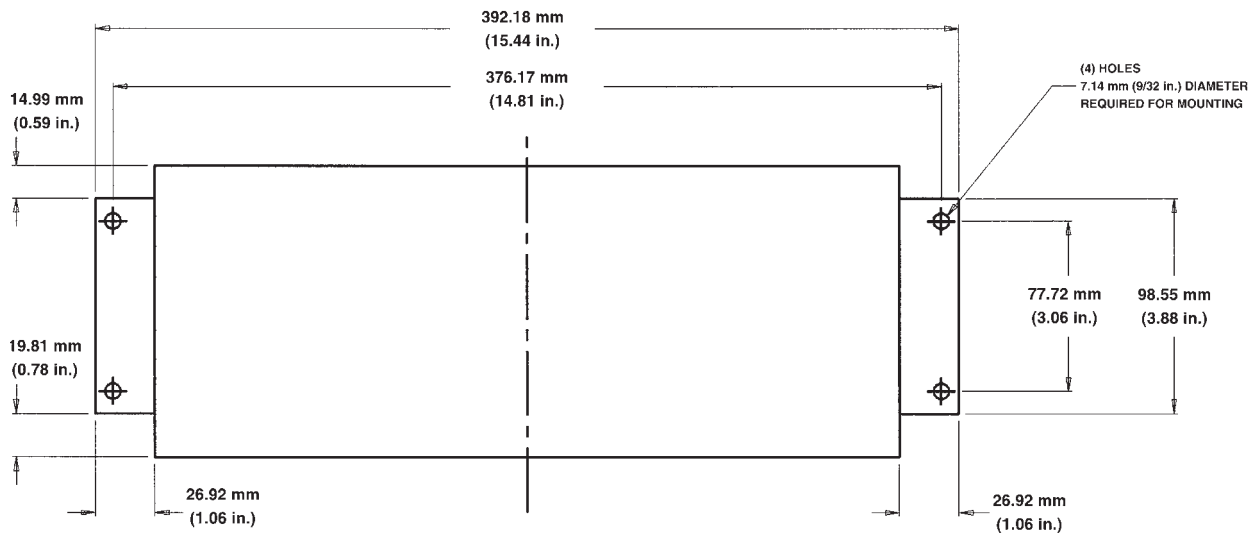

"X" Series Pump Control Panel Mounting Hole Location Dimensions

"I" SERIES PUMP MOUNTING DRAWINGS

The following pages contain drawings to assist in the installation of "I" Series pumps on apparatus. The drawings are not to scale but will assist the installer in locating mounting holes and determining compartment size for the pumps.

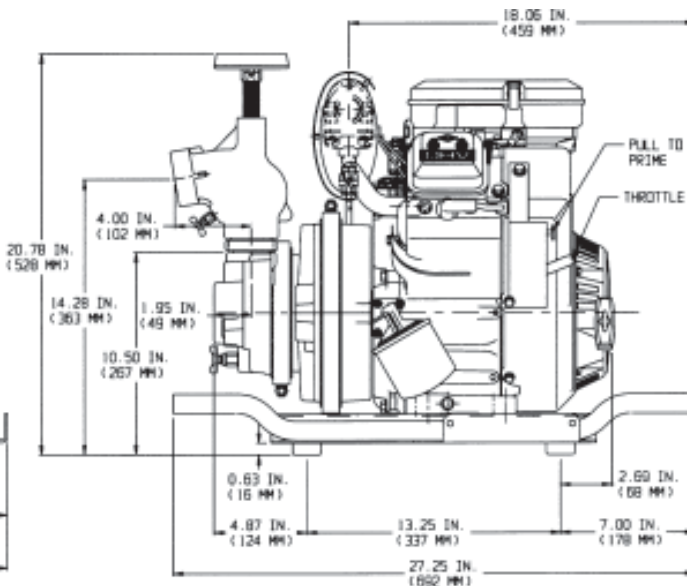
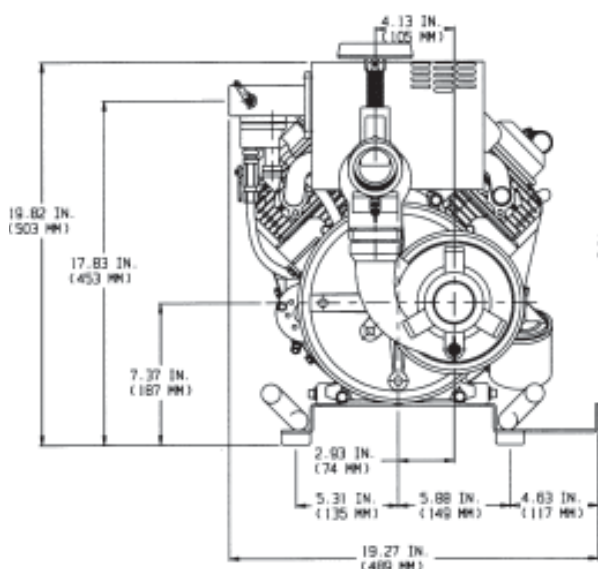

HP100I

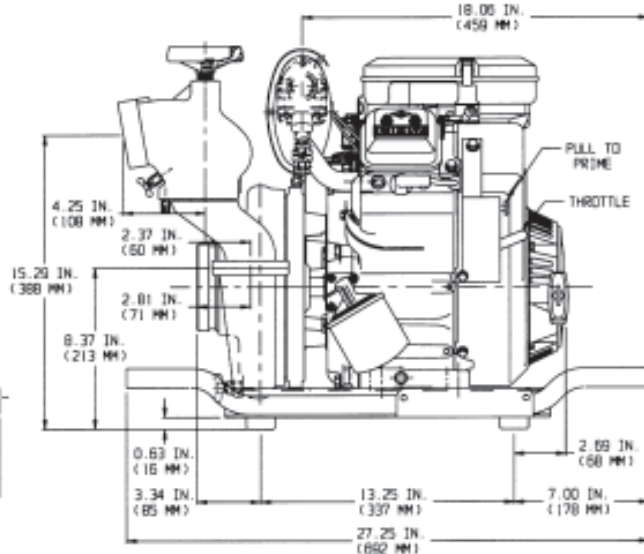
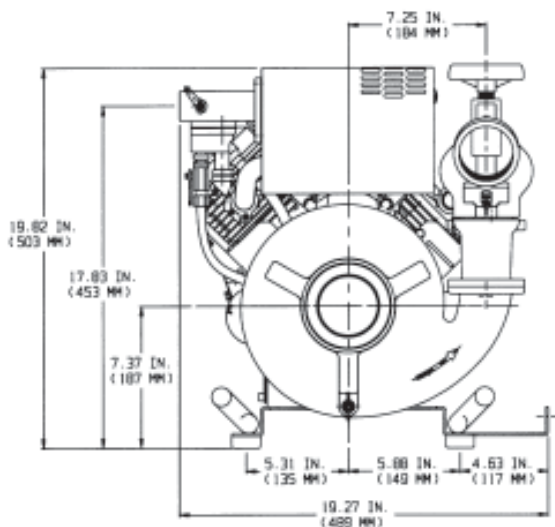

HP200I

"I" Series Pump Dimensions

**HP SERIES
PORTABLE PUMPS**

USER OPERATION AND MAINTENANCE

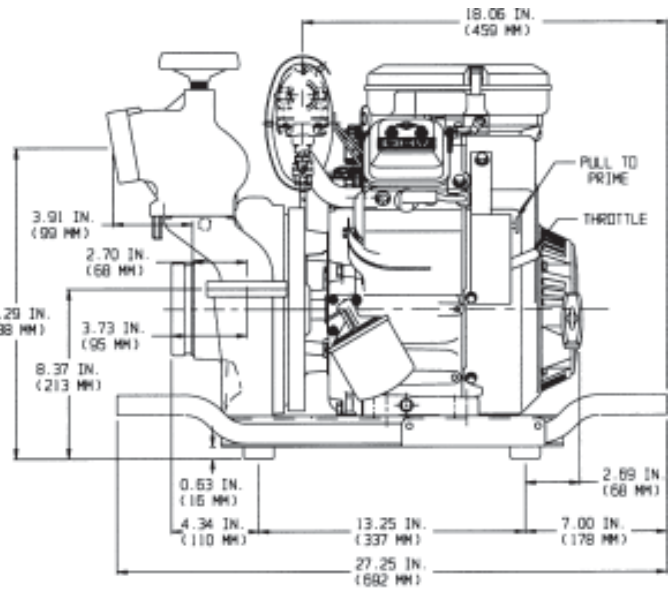
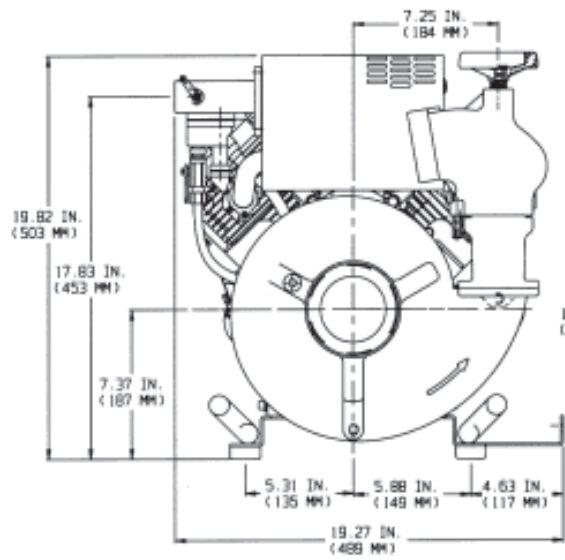

HP300I

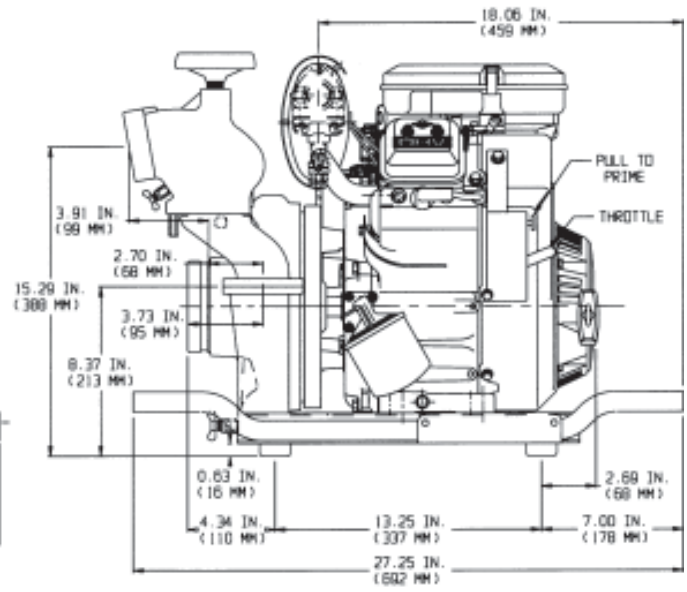
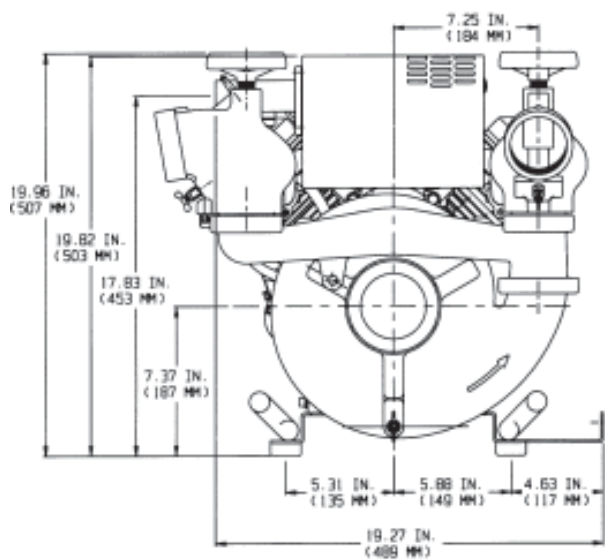

HP400I

"I" Series Pump Dimensions

12 ELECTRICAL WIRING DIAGRAMS

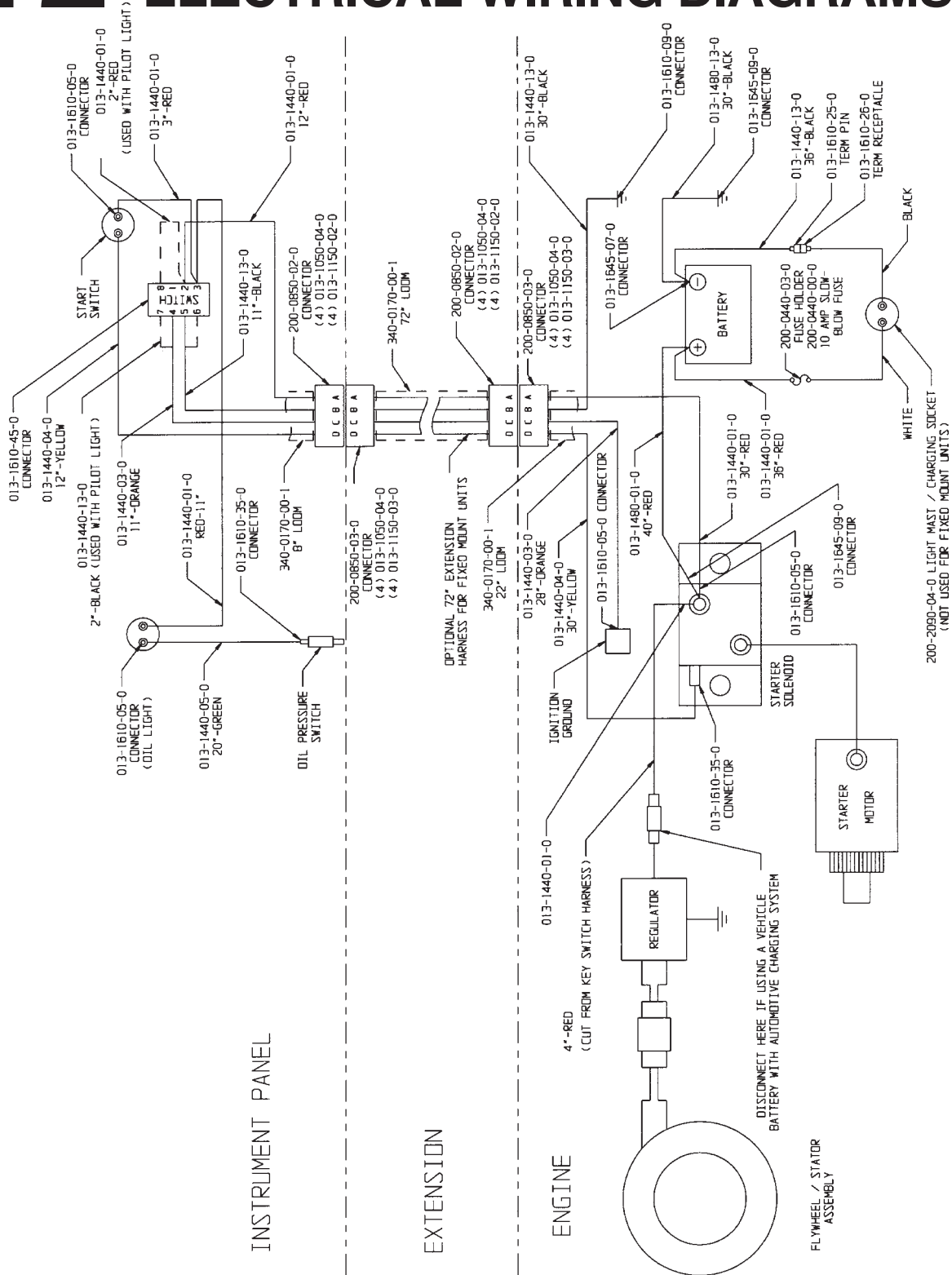

HP SERIES PORTABLE PUMPS

USER OPERATION AND MAINTENANCE

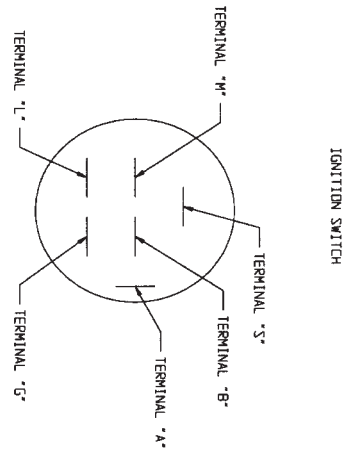

- TERMINAL "A" - RED WIRE TO REGULATOR
- TERMINAL "B" - ORANGE WIRE TO BATTERY
- TERMINAL "S" - YELLOW WIRE TO STARTER SOLENOID
- TERMINAL "H" - BLACK WIRE TO ENGINE GROUND
- TERMINAL "L" - WHITE WIRE TO FUEL SOLENOID (NOT USED)
- TERMINAL "G" - NOT USED

KEY POSITION	CIRCUIT
OFF	G+H+A
RUN	B+L+A
START	B+L+S

NOTE: TO INSTALL, REMOVE INSTRUMENT PANEL, DISCONNECT KEY-SWITCH WIRING HARNESS AND CONNECT SUPPLIED REMOTE HARNESS PER HP AND HP-X SERIES WIRING DIAGRAM.

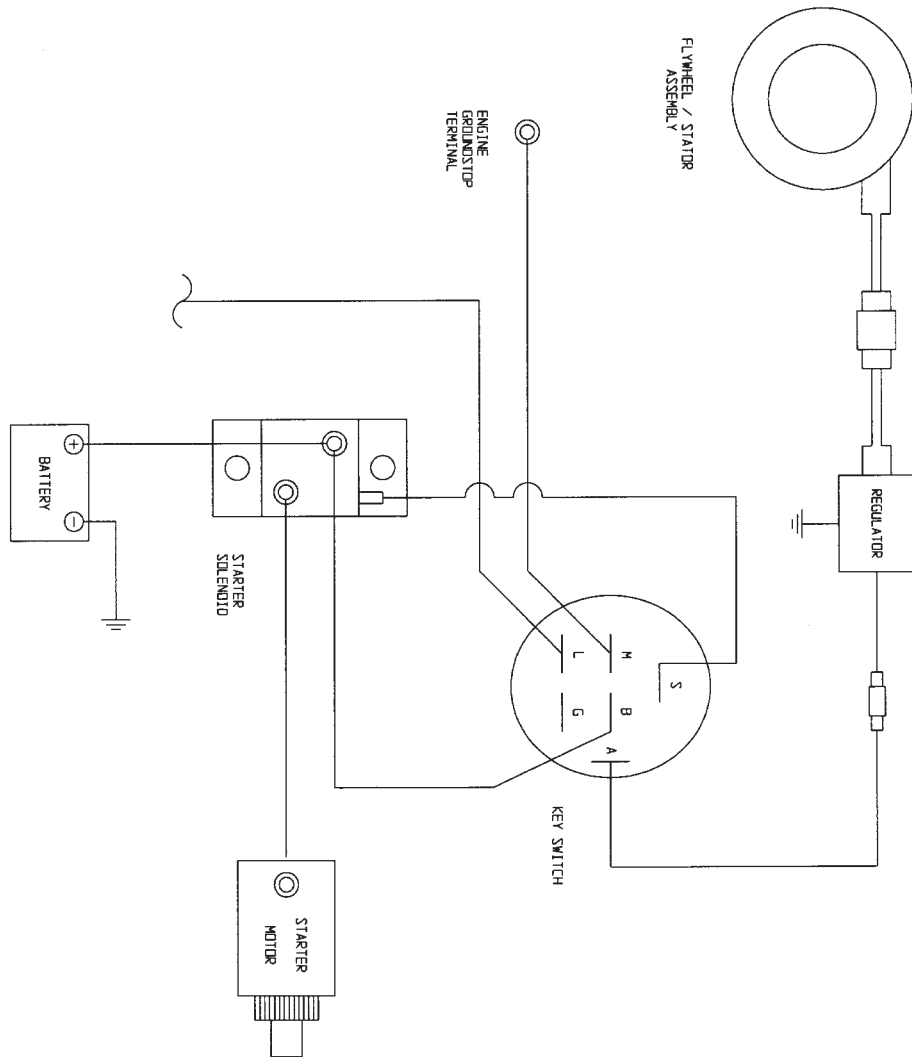

HP" Series Electrical Wiring Diagram

13 PARTS LIST

The following pages contain exploded views of the HP Portable, "X" Series and "I" Series pumps. Each part of the pump is identified on the illustration with an index number. Located in the list on the page next to the illustration are the Hale Products Inc. part numbers for the component parts. When repairing the pump refer to these exploded views to identify the part numbers of components requiring replacement.

**HP SERIES
PORTABLE PUMPS**

USER OPERATION AND MAINTENANCE

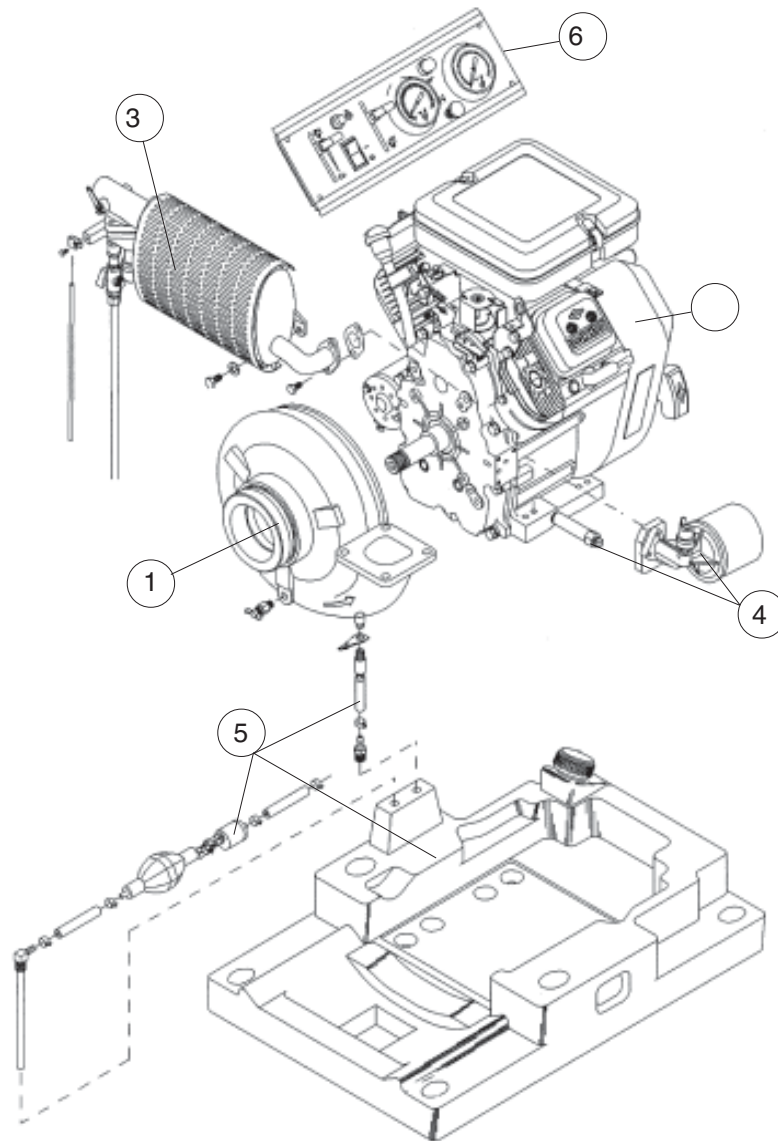

PL-1: HP SERIES PUMP COMPONENT IDENTIFICATION

PL-1: HP SERIES PUMP COMPONENT IDENTIFICATION

ITEM	PART NUMBER	DESCRIPTION	QTY	UNIT
	545-4050-00-0	HP100 PORTABLE PUMP		EA
	545-4050-02-0	HP100X PORTABLE PUMP		EA
	545-4060-00-0	HP200 PORTABLE PUMP		EA
	545-4060-02-0	HP200X PORTABLE PUMP		EA
	545-4070-00-0	HP300 PORTABLE PUMP		EA
	545-4070-02-0	HP300X PORTABLE PUMP		EA
	545-4080-00-0	HP400 PORTABLE PUMP		EA
	545-4080-02-0	HP400X PORTABLE PUMP		EA
1		HP SERIES PUMP END (FOR DETAILS SEE: PL-3 FOR HP200, HP300 AND HP400: PL-4 FOR HP100)	1.0	EA
2	045-0680-00-0	B&S MODEL 350447-0080 ENG (B35) (FOR MOUNTING DETAILS SEE PL-8)	1.0	EA
3	538-1520-00-0	EXHAUST PRIMER ASSEMBLY (FOR DETAILS SEE PL-7)	1.0	EA
4		OIL FILTER AND DRAIN ASSEMBLY (FOR DETAILS SEE PL-11)	1.0	EA
5	503-1340-00-0	FUEL SYSTEM (FOR DETAILS SEE PL-10)	1.0	EA
6	168-0070-13-0	HP X SERIES INSTRUMENT PANEL ASSEMBLY (FOR DETAILS SEE PL-9)	1.0	EA

**HP SERIES
PORTABLE PUMPS**

USER OPERATION AND MAINTENANCE

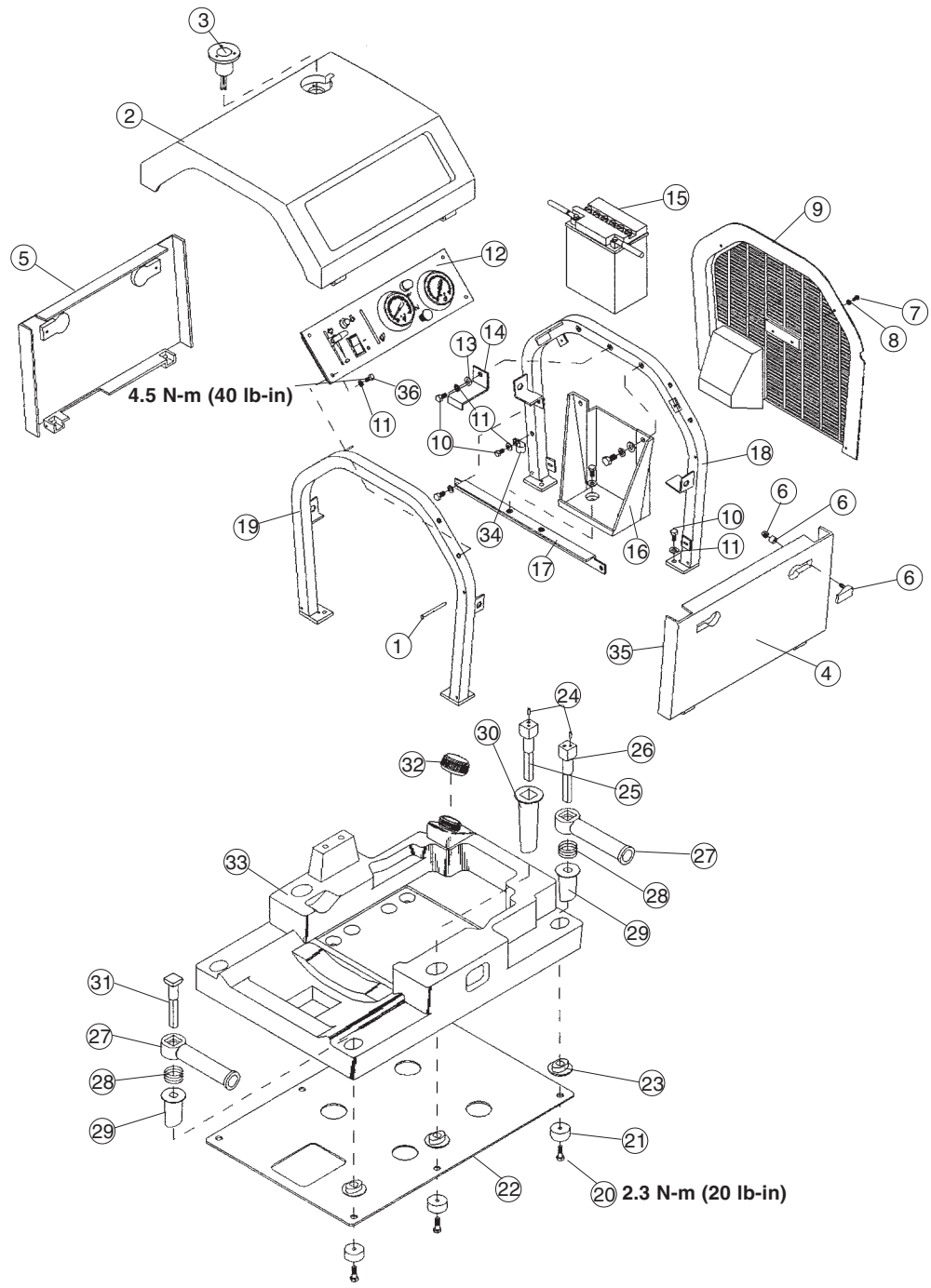

PL-2: HP SERIES PORTABLE PUMP COVERS AND CARRYING HANDLES

HP SERIES PORTABLE PUMP COVERS AND CARRYING HANDLES

ITEM	PART NUMBER	DESCRIPTION	QTY	UNIT
1	064-6320-01-0	HINGE/RELEASE PIN	6.0	EA
2	070-0020-24-0	PORTABLE PUMP COVER	1.0	EA
3	200-2090-04-0	LIGHT MAST/CHARGING SOCKET	1.0	EA
4	070-0030-28-0	PORTABLE PUMP SIDE PANEL	1.0	EA
5	070-0030-31-0	PORTABLE PUMP SIDE PANEL	1.0	EA
6	242-0250-01-0	SIDE PANEL SWELL LATCH	6.0	EA
7	218-0406-48-0	SCREW M4-.7 X 12 PHILLIP HD SST	8.0	EA
8	097-1900-00-0	WASHER-#8 300 SERIES SST FLAT	6.0	EA
9	070-0030-29-0	REAR GRILL	1.0	EA
10	218-0810-12-0	SCREW M8-1.25 X 20 H.H. SST	7.0	EA
11	097-0560-02-0	WASHER 5/16, 300 SER SST LOCK	6.0	EA
12	168-0070-10-0	INSTR. PANEL ASSEMBLY (FOR DETAILS SEE PL-9)	1.0	EA
13	097-0810-01-0	WASHER-5/16 STL ZINC PL FLAT	16.0	EA
14	047-0170-08-0	BATTERY HOLD-DOWN	1.0	EA
15	200-0600-00-0	BATTERY	1.0	EA
16	047-0030-10-0	BATTERY BASE	1.0	EA
17	019-0740-01-0	BATTERY SUPPORT BRACKET	1.0	EA
18	547-0910-01-0	FRAME MEMBER-REAR	1.0	EA
19	547-0910-00-0	FRAME MEMBER-FRONT	1.0	EA
20	218-0812-12-0	SCREW M8-1.25 X 25 H.H. SST NYLOCK	6.0	EA
21	097-0520-00-0	1-FZZ-264A RUBBER PAD #1019-2W	6.0	EA
22	047-0200-02-0	UNIT MOUNTING BASE	1.0	EA
23	048-1180-03-0	HANDLE SLEEVE BASE	6.0	EA
24	064-0612-12-0	03-64H-06S PIN	5.0	EA
25	019-0390-07-0	HANDLE SPRT BRKT	2.0	EA
26	019-0390-04-0	HANDLE SPRT BRKT	2.0	EA
27	512-0080-02-0	HANDLE ASSEMBLY	4.0	EA
28	042-0500-01-0	HANDLE SPRING	4.0	EA
29	048-1180-01-0	HANDLE SLEEVE	4.0	EA
30	048-1180-02-0	HANDLE SLEEVE-CENTER	2.0	EA
31	019-0390-05-0	HANDLE SPRT BRKT(FR)	2.0	EA
32	008-0300-02-0	FUEL TANK CAP-2"	1.0	EA
33	108-0560-00-0	FUEL TANK PORTABLE PUMP	1.0	EA
34	242-0380-00-0	TUBING CLAMP	1.0	EA
35	101-1470-09-0	LABEL, HP OPERATING INSTRUCTIONS	1.0	EA
36	218-0612-02-0	SCREW M6-1.25 X 20 HH SST	4.0	EA

**HP SERIES
PORTABLE PUMPS**

USER OPERATION AND MAINTENANCE

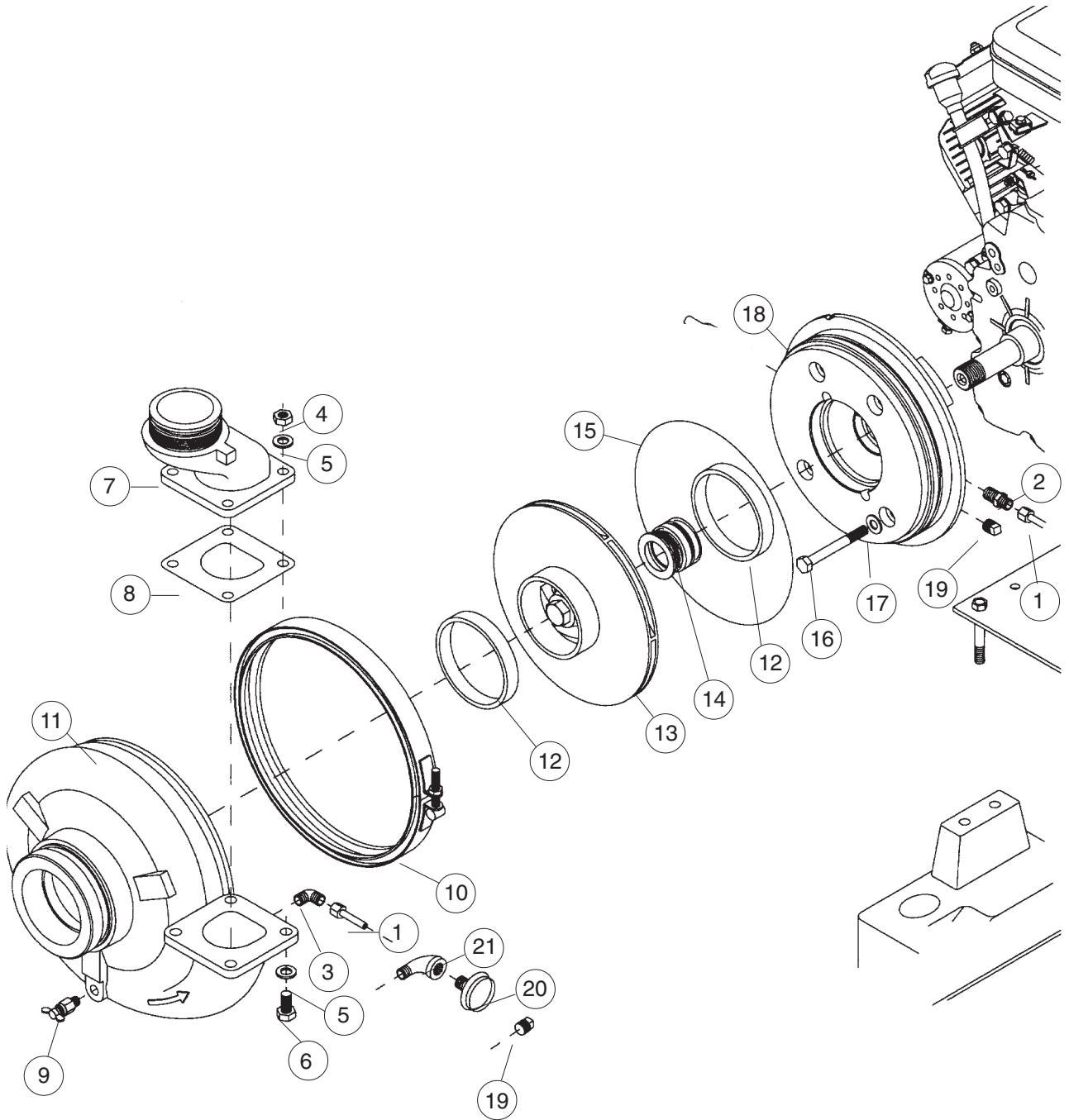

HP200, HP300 AND HP400 PUMP END

ITEM	PART NUMBER	DESCRIPTION	QTY	UNIT
1	604-0079-00-0	1/4 ODX.040 THERMOPLASTIC TUBING	2.9	FT
2	082-0262-11-0	CONNECTOR-1/4 NPT X 1/4 TUBE PLTD	1.0	EA
3	082-0261-11-0	ELBOW 1/4 MNPT X 1/4 TUBE, PUSH	1.0	EA
4	210-1000-02-0	5504-1000 NUT M-10 X 1.5	4.0	EA
5	097-1070-00-0	WASHER 7/16 ZINC PL STL FLAT	8.0	EA
6	218-1015-02-0	SCREW M10-1.5 X 30 H.H.ZINC PL	4.0	EA
7	007-2080-01-0	HP300 DISCH. VALVE ADAPTER (HP200 AND HP300 PORTABLE PUMPS)	1.0	EA
	178-0370-00-0	HP400 DISCHARGE MANIFOLD (HP400 PORTABLE PUMP)	1.0	EA
	115-0070-00-0	115-2 1/2 FLANGE (HP200 "X" SERIES)	1.0	EA
	115-0080-00-0	115-3 FLANGE (HP300 AND HP400 "X" SERIES)	1.0	EA
8	046-0050-00-0	46DW GASKET	1.0	EA
9	038-1270-01-0	1/4 DRAIN VALVE-PLTD BRASS	1.0	EA
10	242-0880-00-0	V-BAND CLAMP (10.125 IN. DIAMETER)	1.0	EA
11	001-0780-00-0	HP300/400 PUMP VOLUTE	1.0	EA
	001-0810-00-0	HP200 PUMP VOLUTE	1.0	EA
12	321-0070-00-0	FZ-321 CLEARANCE RING	2.0	EA
13	016-0960-01-0	HP200 IMPELLER	1.0	EA
	016-0960-00-0	HP300 IMPELLER	1.0	EA
	016-0970-00-0	HP400 IMPELLER	1.0	EA
14	296-5250-00-0	MECH.SEAL 1-3/8" SHAFT TYPE 21	1.0	EA
15	040-2680-00-0	-268 NITRILE SEAL RING	1.0	EA
16	018-1632-17-0	SCREW 3/8-16 X 3-1/4 H.H. SST LOCK	4.0	EA
17	097-0200-06-0	SEALING WASHER-3/8" SST	4.0	EA
18	002-0630-00-0	PUMP HEAD	1.0	EA
HP "I" COMPONENTS				
19	217-0201-00-0	1/4 INCH NPT PIPE PLUG (2 REQUIRED FOR IX PUMPS)	1.0	EA
20	168-0040-13-0	PRESSURE GUAGE	1.0	EA
21	082-0211-00-0	ELBOW, 1/4 INCH NPT SERVICE	1.0	EA
	546-1740-00-0	LEVEL 1 SPARE PARTS KIT (GASKETS & SEALS)		

**HP SERIES
PORTABLE PUMPS**

USER OPERATION AND MAINTENANCE

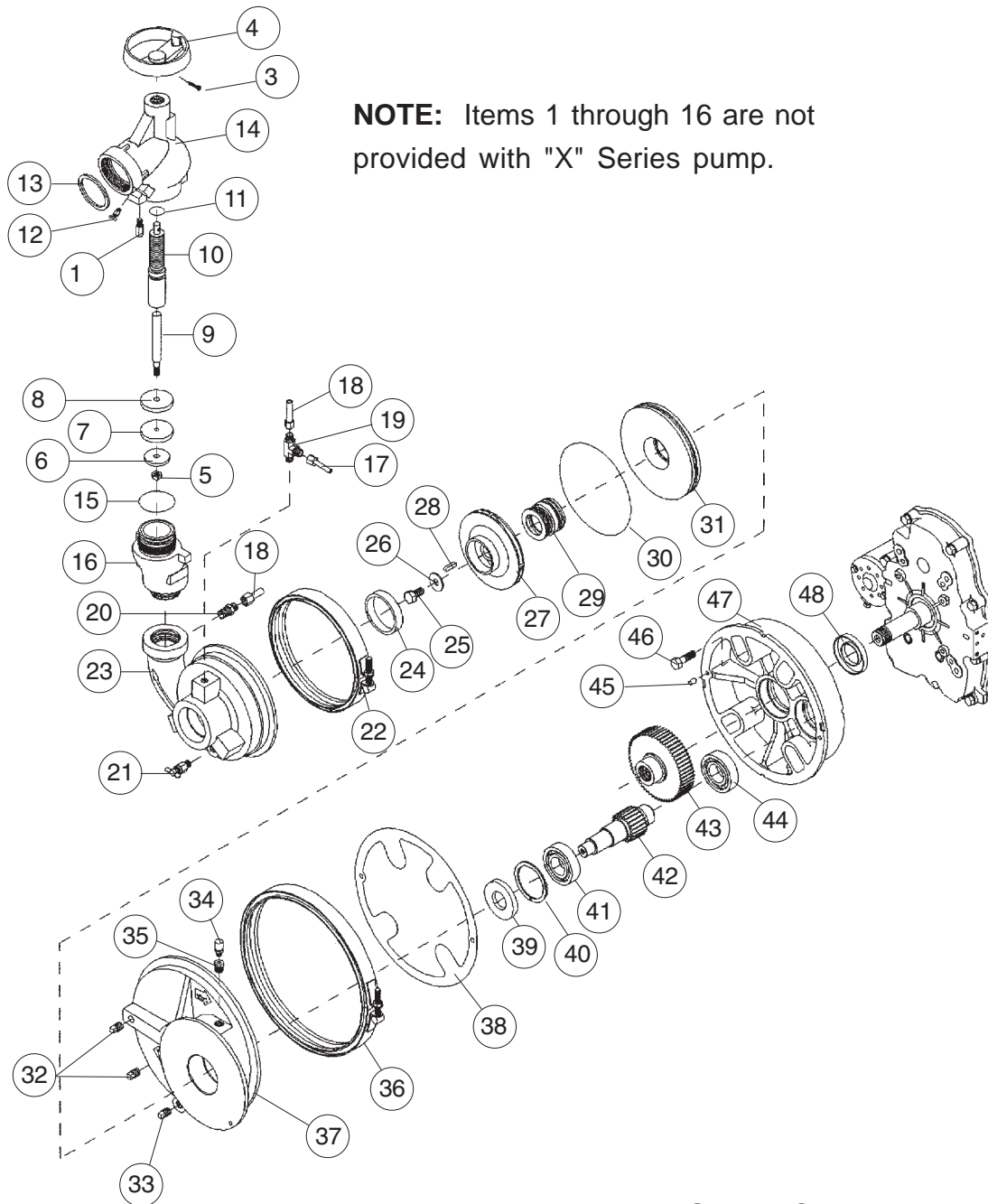

NOTE: Items 1 through 16 are not provided with "X" Series pump.

PL-4: HP100 PUMP END AND GEARBOX

ITEM	PART NUMBER	DESCRIPTION	QTY	UNIT
1	018-8250-00-0	STUD-HP SERIES VALVE STOP M8	1.0	EA
2	538-1450-01-0	HP100 DISCHARGE VALVE ASSEMBLY	1.0	EA
3	218-0408-19-0	SCREW M4-.7X16 SOC.HD. LOCK	1.0	EA
4	012-0170-02-0	HANDWHEEL-HP SERIES DISCHARGE	1.0	EA
5	210-0805-11-0	NUT M8-1.25 STNLS STL LOCKING	9.0	EA
6	097-1750-03-0	HP100 VALVE WASHER	1.0	EA
7	097-1760-01-0	HP100 VALVE SEAL WASHER	1.0	EA
8	097-1750-02-0	HP100 VALVE BACKUP WASHER	1.0	EA

HP100 PUMP END AND GEARBOX

ITEM	PART NUMBER	DESCRIPTION	QTY	UNIT
9	041-0480-00-0	HP SERIES VALVE STEM	1.0	EA
10	041-0470-00-0	HP SERIES VALVE SHAFT	1.0	EA
11	040-2100-00-0	2308-210 O-RING	1.0	EA
12	038-1220-01-0	1/8 DRAIN VALVE-PLTD BRASS	1.0	EA
13	097-1840-00-0	2 INCH ISO(BSP) SEAL WASHER	1.0	EA
14	038-1600-00-0	HP100 DISCHARGE VALVE BODY	1.0	EA
15	040-2250-00-0	40-4N187 (3P-400) SEAL RING	1.0	EA
16	007-2080-00-0	HP100 DISCH. VALVE ADAPTER	1.0	EA
17	604-0079-00-0	1/4 ODX.040 THERMOPLASTIC TUBING	2.9	FT
18	604-0033-00-0	3/8 OD X.032 WALL COPPER TUBE	1.0	FT
19	082-0209-02-0	TEE- 1/4 FNPT BRASS	1.0	EA
20	082-0206-02-0	CONNECTOR-1/4NPT TO 3/8 TUBING	1.0	EA
21	038-1270-01-0	1/4 DRAIN VALVE-PLTD BRASS	1.0	EA
22	242-0880-01-0	V-BAND CLAMP (7.125 DIA.)	1.0	EA
23	001-0790-00-0	HP100 PUMP VOLUTE	1.0	EA
24	321-0430-00-0	HP100 CLEARANCE RING	1.0	EA
25	218-1012-17-0	SCREW M10 X 25 HH SST NY-LOCK	1.0	EA
26	097-0380-01-0	HP100 IMPELLER WASHER	1.0	EA.
27	016-0980-00-0	HP100 IMPELLER	1.0	EA
28	017-0260-01-0	HP100 IMPELLER KEY	1.0	EA
29	296-5050-06-0	HP100 MECHANICAL SEAL	1.0	EA
30	040-2540-00-0	-254 NITRILE SEAL RING	1.0	EA
31	002-0640-00-0	HP100 PUMP HEAD	1.0	EA
32	217-0201-00-0	1/4 NPT SQUARE HEAD STEEL PLUG	2.0	EA
33	217-0201-08-0	1/4 NPT MAGNETIC PLUG	1.0	EA
34	044-0260-02-0	1/8 AIR VENT-NO CHECK	1.0	EA
35	082-0214-00-0	BUSHING 1/4 X 1/8 NPT STEEL	1.0	EA
36	242-0880-00-0	V-BAND CLAMP (10.125 DIA.)	1.0	EA
37	004-0490-01-0	HP100 GEARBOX (PUMP SIDE)	1.0	EA
38	046-1570-00-0	HP100 GEARBOX GASKET	1.0	EA
39	296-2720-00-0	METRIC OIL SEAL(30MM X 62 X 7)	1.0	EA
40	077-2440-00-0	79S244 (12M-79) RETAINING RING	1.0	EA.
41	250-0206-20-0	206W BEARING	1.0	EA
42	037-1840-00-0	HP100 PUMP SHAFT	1.0	EA
43	031-1180-00-0	HP100 DRIVE GEAR	1.0	EA
44	250-0206-20-0	206W BEARING	1.0	EA
45	064-6020-01-0	0.25DIA X .375 LG DOWEL PIN	2.0	EA
46	018-1612-07-0	SCR-3/8-16X1 1/4LG.HEX.LOCKING	4.0	EA
47	004-0490-00-0	HP100 GEARBOX (INPUT SIDE)	1.0	EA
48	296-2720-01-0	METRIC OIL SEAL(35MM X 62 X 7)	1.0	EA
	538-1450-51-0	HP100 DISCHARGE VALVE ASSEMBLY	1.0	EA
	546-1740-01-0	LEVEL 1 SPARE PARTS KIT (GASKETS & SEALS)		

**HP SERIES
PORTABLE PUMPS**

USER OPERATION AND MAINTENANCE

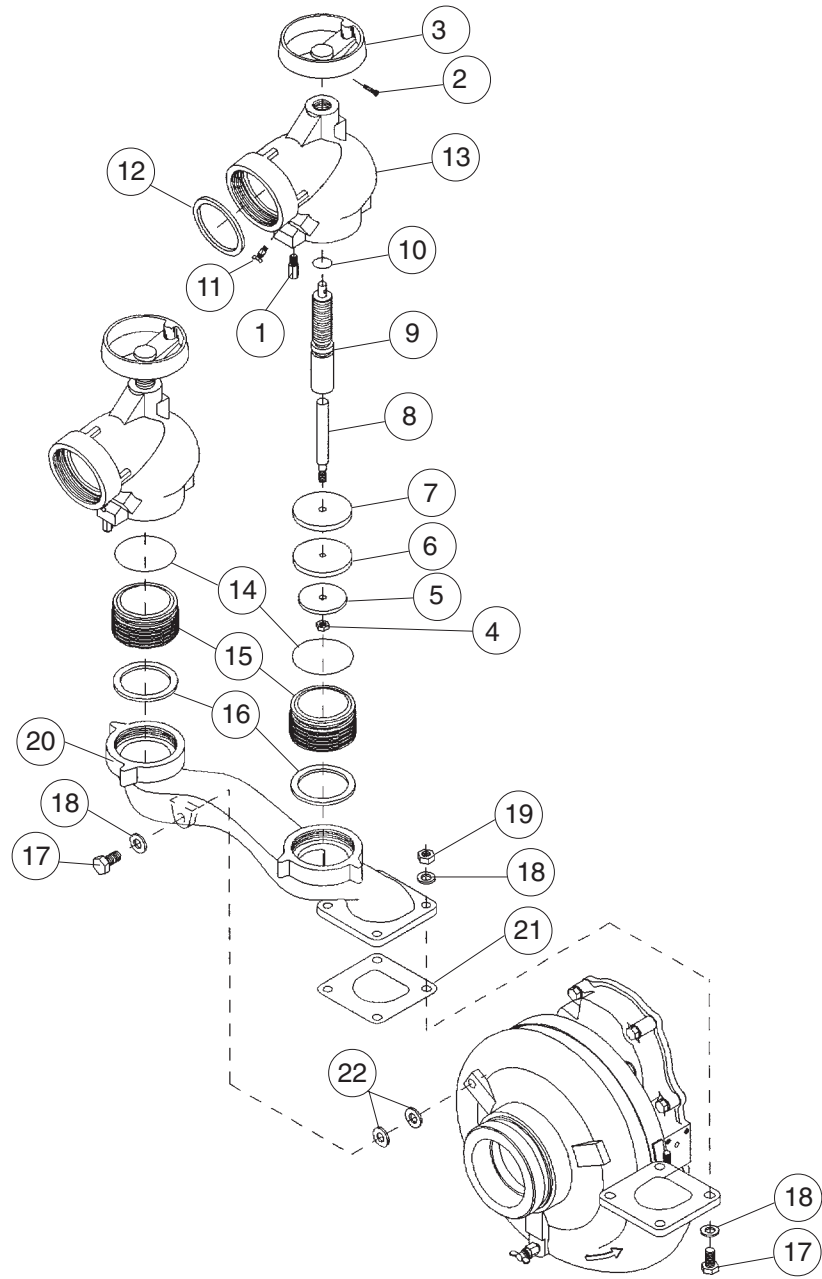

PL-5: HP400 DISCHARGE MANIFOLD

HP400 DISCHARGE MANIFOLD

ITEM	PART NUMBER	DESCRIPTION	QTY	UNIT
1	018-8250-00-0	STUD-HP SERIES VALVE STOP M8	2.0	EA
2	218-0408-19-0	SCREW M4-.7X16 SOC.HD. LOCK	2.0	EA
3	012-0170-02-0	HANDWHEEL-HP SERIES DISCHARGE	2.0	EA
4	210-0805-11-0	NUT M8-1.25 STNLS STL LOCKING	8.0	EA
5	097-1750-01-0	HP300 VALVE WASHER	2.0	EA
6	097-1760-00-0	HP300 VALVE SEAL WASHER	2.0	EA
7	097-1750-00-0	HP300 VALVE BACKUP WASHER	2.0	EA
8	041-0480-00-0	VALVE STEM	2.0	EA
9	041-0470-00-0	VALVE SHAFT	2.0	EA
10	040-2100-00-0	2308-210 O-RING	1.0	EA
11	038-1220-01-0	1/8 DRAIN VALVE-PLTD BRASS	2.0	EA
12	097-1840-01-0	2.5 INCH ISO (BSP) SEAL WASHER	4.0	EA
13	038-1510-00-0	HP300 DISCHARGE VALVE BODY	2.0	EA
14	040-2310-00-0	-231 NITRILE SEAL RING	2.0	EA
15	007-2080-02-0	HP400 DISCHARGE VALVE ADAPTER	2.0	EA
16	097-1840-01-0	2.5 INCH ISO (BSP) SEAL WASHER	4.0	EA
17	218-1015-02-0	SCREW M10-1.5 X 30 H.H.ZINC PL	5.0	EA
18	097-1070-00-0	WASHER 7/16 ZINC PL STL FLAT	9.0	EA
19	210-1000-02-0	NUT M-10 x 1.5 ZINC PL STL	4.0	EA
20	178-0370-00-0	HP400 DISCHARGE MANIFOLD	1.0	EA
21	046-0050-00-0	46DW GASKET	1.0	EA
22	097-1830-00-0	SPHERICAL WASHER SET	1.0	EA

**HP SERIES
PORTABLE PUMPS**

USER OPERATION AND MAINTENANCE

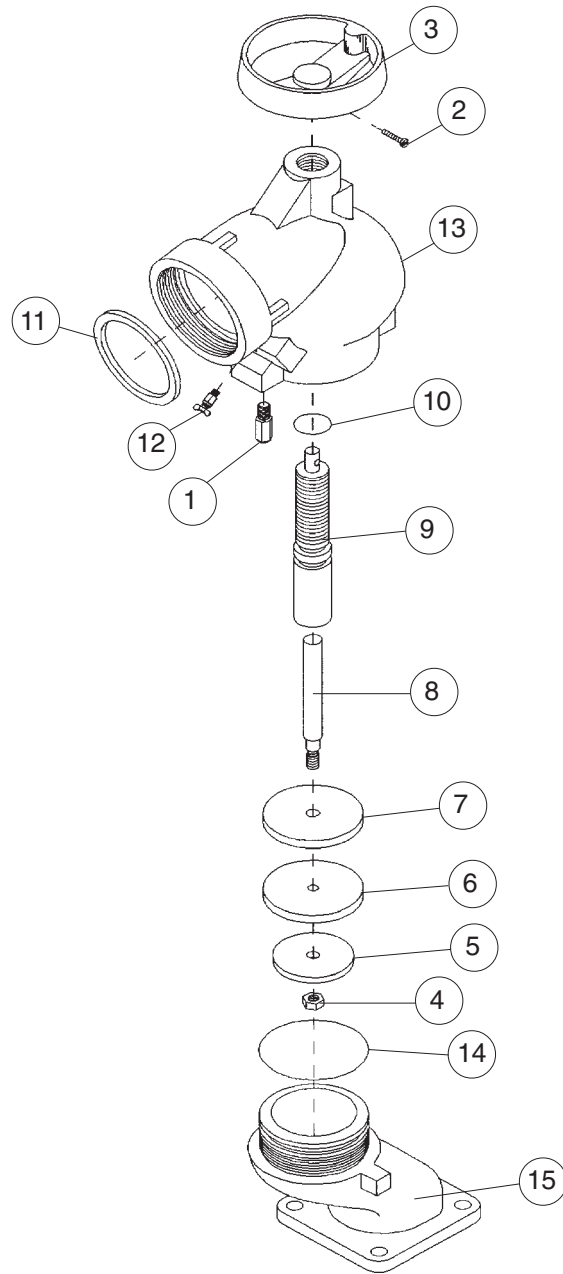

PL-6: HP300 DISCHARGE VALVE ASSEMBLY

HP300 DISCHARGE VALVE ASSEMBLY

ITEM	PART NUMBER	DESCRIPTION	QTY	UNIT
1	018-8250-00-0	STUD-HP SERIES VALVE STOP M8	1.0	EA
2	218-0408-19-0	SCREW M4-.7X16 SOC.HD. LOCK	1.0	EA
3	012-0170-02-0	HANDWHEEL-HP SERIES DISCHARGE	1.0	EA
4	210-0805-11-0	NUT M8-1.25 STNLS STL LOCKING	8.0	EA
5	097-1750-01-0	HP300 VALVE WASHER	1.0	EA
6	097-1760-00-0	HP300 VALVE SEAL WASHER	1.0	EA
7	097-1750-00-0	HP300 VALVE BACKUP WASHER	1.0	EA
8	041-0480-00-0	VALVE STEM	1.0	EA
9	041-0470-00-0	VALVE SHAFT	1.0	EA
10	040-2100-00-0	2308-210 O-RING	1.0	EA
11	097-1840-01-0	2.5 INCH ISO(BSP) SEAL WASHER	1.0	EA
12	038-1220-01-0	1/8 DRAIN VALVE-PLTD BRASS	1.0	EA
13	038-1510-00-0	HP300 DISCHARGE VALVE BODY	1.0	EA
14	040-2310-00-0	-231 NITRILE SEAL RING	1.0	EA
15	007-2080-01-0	HP300 DISCH. VALVE ADAPTER	1.0	EA
16	568-1450-50-0	REPLACEMENT DISCHARGE VALVE ASSEMBLY (NOT SHOWN)		

**HP SERIES
PORTABLE PUMPS**

USER OPERATION AND MAINTENANCE

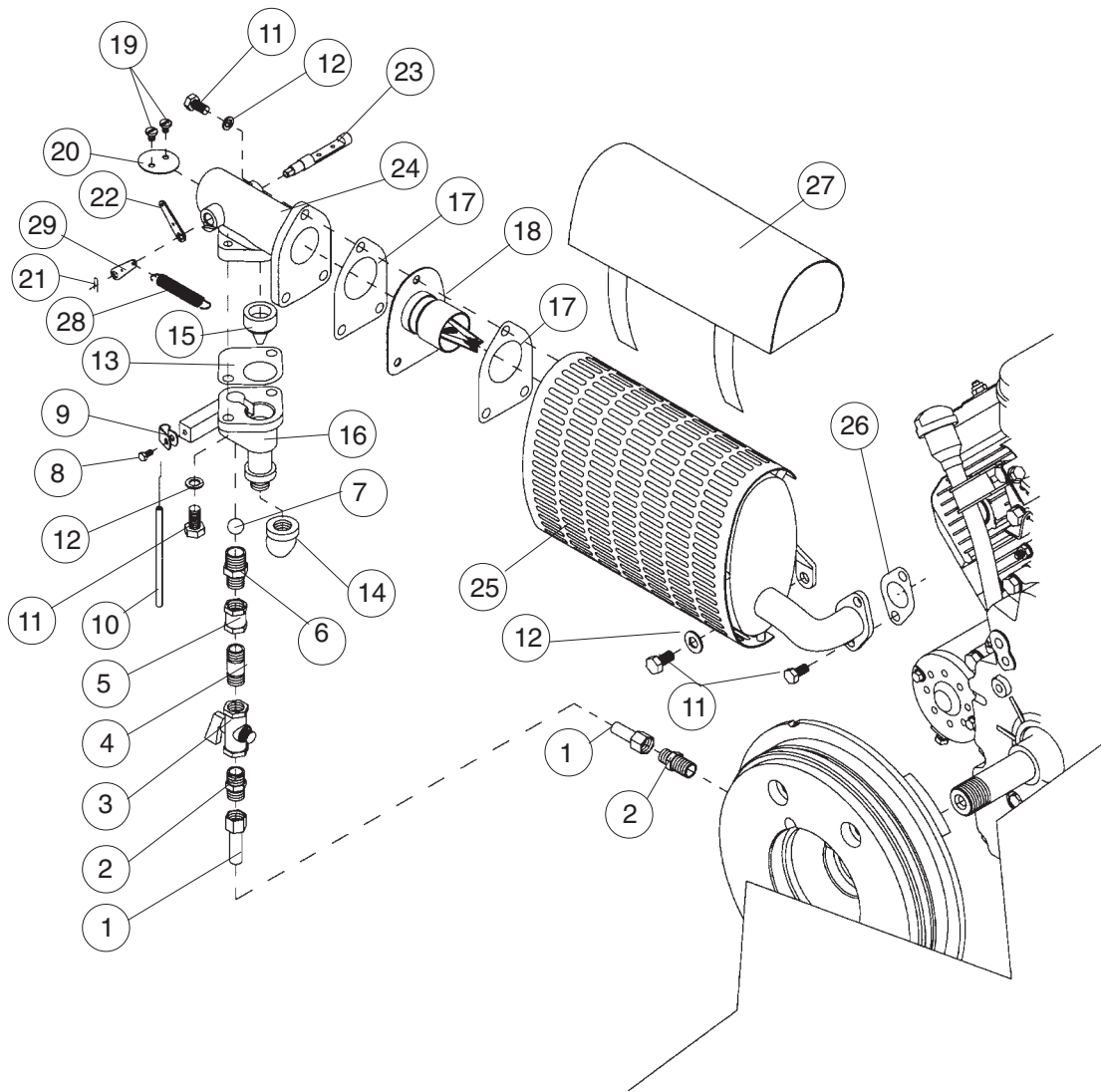

PL-7: HP SERIES PUMP EXHAUST PRIMER ASSEMBLY

HP SERIES PUMP EXHAUST PRIMER ASSEMBLY

ITEM	PART NUMBER	DESCRIPTION	QTY	UNIT
1	604-0033-00-0	3/8 OD X.032 WALL COPPER TUBE	1.0	FT
2	082-0206-02-0	CONNECTOR-1/4NPT TO 3/8 TUBING	1.0	EA
3	038-1130-00-0	1/4 NPT FEMALE BALL VALVE	1.0	EA
4	082-0212-02-0	NIPPLE-1/4 NPT PLTD BRS 38 MM (1.5 IN.) LG	3.0	EA
5	082-0215-02-0	COUPLING 1/4 NPT BRASS	1.0	EA
6	276-0230-00-0	CHECK VALVE SEAT	1.0	EA.
7	039-0200-03-0	CHECK BALL-3/8 DIA VITON	1.0	EA
8	218-0404-48-0	SCREW M4-.7 X 8 PHILLIP HD SST	2.0	EA
9	242-0360-01-0	CABLE CLIP	1.0	EA
10	013-0340-10-0	PRIMER CABLE ASSEMBLY (44 IN. LG.) FOR PORTABLE PUMP	1.0	EA
	013-0340-11-0	PRIMER CABLE ASSEMBLY (74-1/4 IN. LG.) FOR "X" SERIES PUMP	1.0	EA
	513-0230-XX-0	PRIMER CABLE ASSEMBLY (XX IN. LG.) FOR "I" SERIES PUMP	1.0	EA
11	218-0812-02-0	SCREW M8-1.25 X 25 H.H. SST	7.0	EA
12	097-0560-02-0	WASHER-5/16 300 SER SST LOCK	6.0	EA
13	046-0850-01-0	EJECTOR GASKET	1.0	EA.
14	082-0348-02-0	ELBOW-3/8 NPT X 1/2 SOLDER	1.0	EA
15	007-0900-01-0	NOZZLE-EJECTOR	1.0	EA
16	038-0500-01-0	BODY-EJECTOR	1.0	EA
17	046-6240-01-0	EXHAUST PRIMER GASKET	2.0	EA
18	010-0300-01-0	SPARK ARRESTOR SCREEN (INCLUDED WITH MUFFLER, ITEM 25)	1.0	EA
19	218-0404-48-0	SCREW M4-.7 X 8 PHILLIP HD SST	1.0	EA
20	038-0550-01-0	EXHAUST VALVE BUTTERFLY	1.0	EA
21	064-6290-01-0	HAIRPIN COTTER PIN-HP EXHAUST	1.0	EA
22	012-0830-01-0	EXHAUST VALVE LEVER (PORTABLE & "X" SERIES)	1.0	EA
	012-0830-01-0	EXHAUST VALVE LEVER ("I" SERIES)	2.0	EA
23	037-0820-01-0	EXHAUST VALVE SHAFT	1.0	EA
24	038-0510-01-0	EXHAUST VALVE BODY	1.0	EA
25	524-0240-00-0	MUFFLER- B&S VANGUARD V-TWIN	1.0	EA
26	B&S-805024	MUFFLER GASKET (INCLUDED WITH ENGINE)	2.0	EA
27	142-1090-00-0	MUFFLER BLANKET	1.0	EA
28	042-0650-01-0	EXHAUST VALVE SPRING ("I" SERIES)	1.0	EA

**HP SERIES
PORTABLE PUMPS**

USER OPERATION AND MAINTENANCE

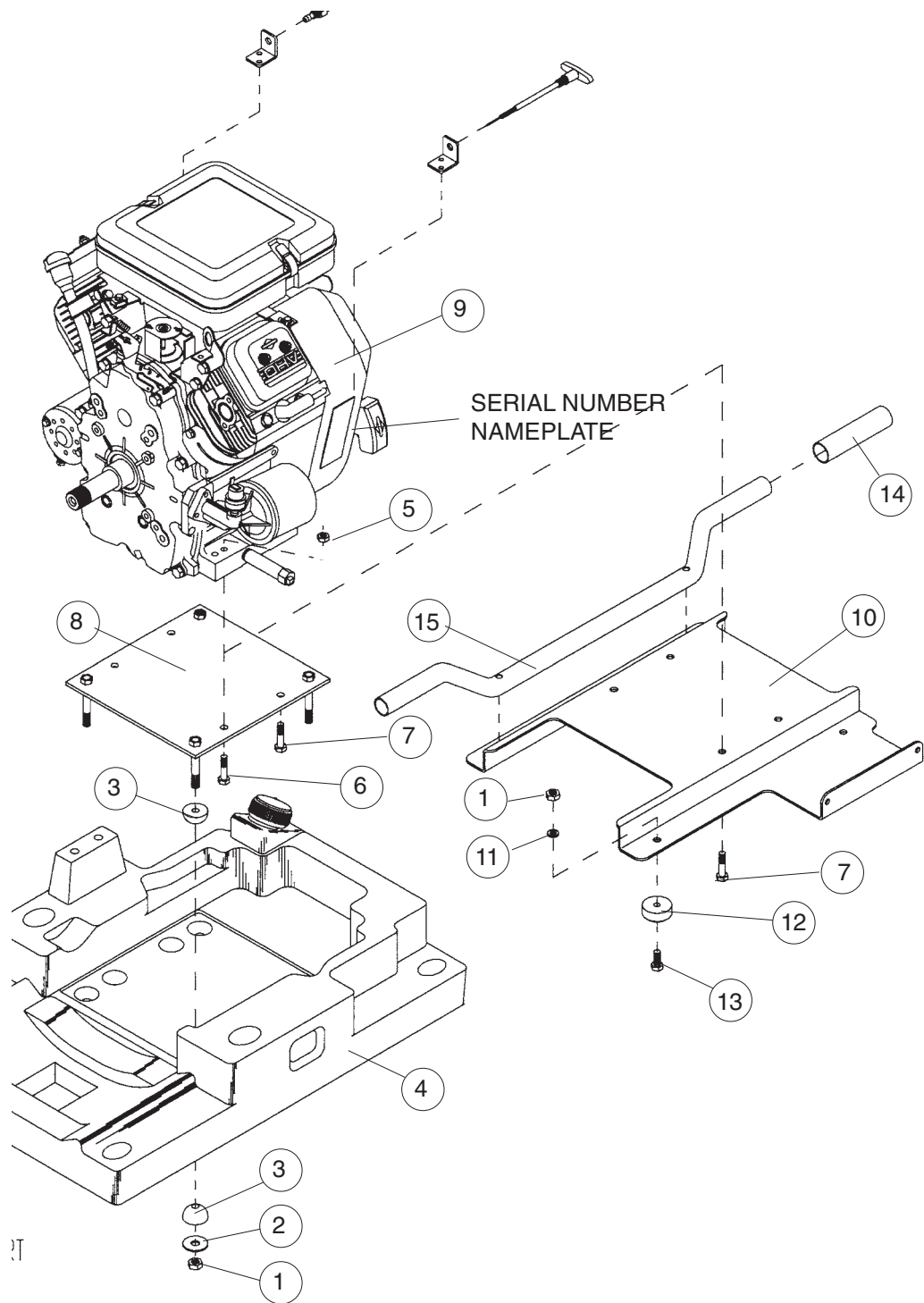

PL-8: HP SERIES PUMP ENGINE MOUNTING

HP SERIES PUMP ENGINE MOUNTING

ITEM	PART NUMBER	DESCRIPTION	QTY	UNIT
1	210-0805-11-0	NUT M8-1.25 SST LOCK	4.0	EA
2	097-1850-00-0	WASHER-.34ID X 1.13OD X .091	12.0	EA
3	048-0800-01-0	VIBRATION MOUNT BUSHING	8.0	EA
4	108-0560-00-0	FUEL TANK PORTABLE PUMP	1.0	EA
5	210-0805-11-0	NUT M8-1.25 SST	4.0	EA
6	218-0822-02-0	SCREW M8-1.25 X 45 HH ZINC PLTD STL	2.0	EA
7	218-0817-12-0	SCREW M8-1.25 X 35 HH SST	2.0	EA
8	047-0200-01-0	ENGINE MOUNTING BASE	1.0	EA
9	045-0680-00-0	B&S MODEL 350447-0080 ENG(B35)	1.0	EA
<u>HP "I" SERIES MOUNTING</u>				
10	547-0190-03-0	BASE - HP "I" SERIES	1.0	EA
11	097-0560-02-0	WASHER, LOCK SST	4.0	EA
12	097-0520-00-0	RUBBER PAD	4.0	EA
13	218-0180-12-0	SCREW M8-1.25 X 20 SST, LOCK	4.0	EA
	218-0822-02-0	SCREW M8-1.25 X 45 HH ZINC PLTD STL (USED WITH HANDLE KIT)	4.0	EA
14	012-0220-00-0	HAND GRIP	4.0	EA
15	512-0080-04-0	OPTIONAL HP "I" SERIES HANDLE	2.0	EA
	512-0080-03-0	OPTIONAL HP "I" SERIES HANDLE KIT	1.0	EA
16	019-0560-02-0	BRACKET	2.0	EA
17	513-0230-02-0	PRIMER CONTROL	1.0	EA
18	088-0250-00-0	FUEL COUPLING	1.0	EA
19	200-0690-03-0	OPTIONAL HP "I" BATTERY KIT WITH MOUNTING	2.0	EA

**HP SERIES
PORTABLE PUMPS**

USER OPERATION AND MAINTENANCE

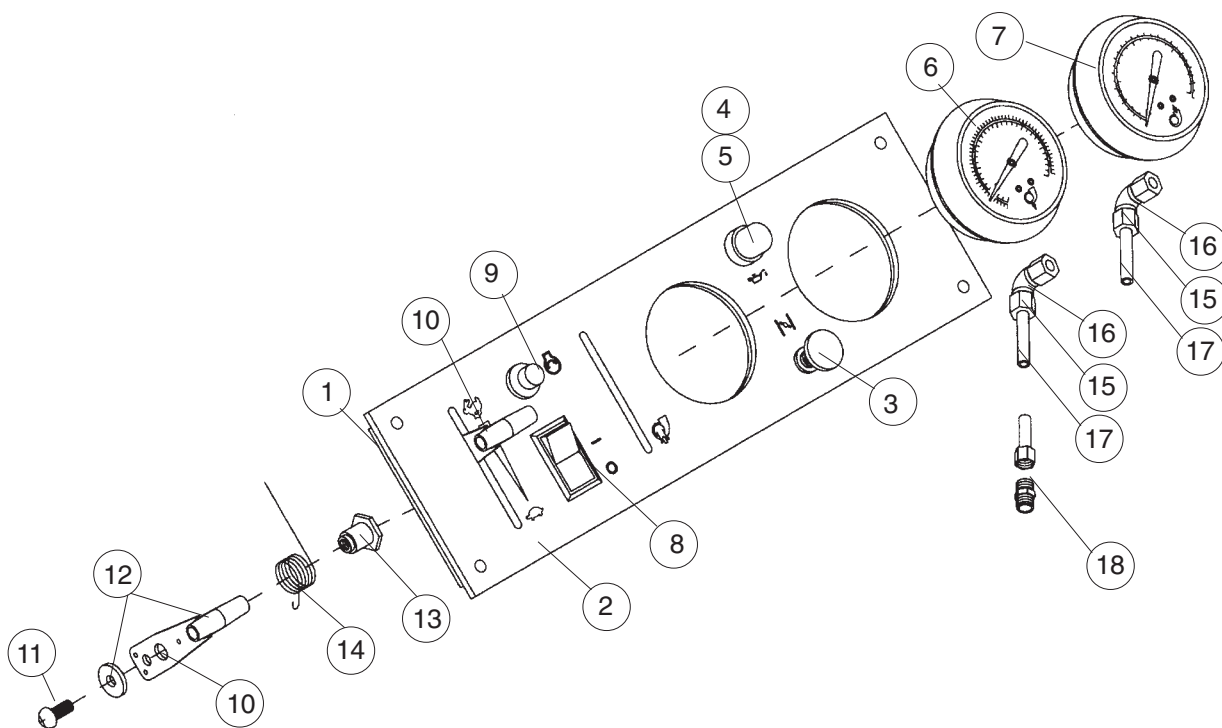

PL-9: INSTRUMENT PANEL ASSEMBLY

ITEM	PART NUMBER	DESCRIPTION	QTY	UNIT
1	019-0320-64-0	INSTRUMENT PANEL SUPPORT PLATE	1.0	EA
2	019-0320-63-0	INSTRUMENT PANEL PLATE	1.0	EA
3	513-0230-00-0	CHOKE CONTROL-18.25" LONG (HP PORTABLE SERIES)	1.0	EA
	513-0230-01-0	CHOKE CONTROL-77.5" LONG (HP X-SERIES)	1.0	EA
4	200-0540-11-0	RED LIGHT ASSY	1.0	EA
5	200-0540-02-0	BULB-14 VOLT 0.24 AMP 3.4 WATT	1.0	EA
6	168-0050-20-0	30-0-150 COMPOUND GAGE,LIQ.FIL A	1.0	EA
7	168-0040-25-0	0-400 DISCH.PRESS.GAGE,LIQ.FIL A	1.0	EA
8	200-0170-01-0	SWITCH-ON/OFF HP SERIES	1.0	EA
9	200-0120-03-0	STARTER SWITCH	1.0	EA
10	013-0340-04-0	THROTTLE/EXHAUST VALVE CONTROL LEVER	2.0	EA
11	018-1205-44-0	SCREW-1/4-20 X5/8	2.0	EA
12	012-0770-00-0	"T" HANDLE, WASHER	2.0	EA
13	110-7530-00-0	NUT-1/4-20 SHOULDER	1.0	EA
14	042-0650-00-0	HP SERIES EXHAUST VALVE SPRING	1.0	EA
15	142-0410-00-0	TUBING INSERT EYLET	2.0	EA
16	604-0079-00-0	1/4 IN OD X 0.040 WALL THERMO TUBING		
		HP PORTABLE COMPOUND GAGE	17.0	IN
		HP PORTABLE DISCHARGE GAGE	19.0	IN
		HP "X" SERIES COMPOUND GAGE	23.0	IN
		HP "X" SERIES DISCHARGE GAGE	29.0	IN
17	042-0650-00-0	ELBOW	2.0	EA
18	092-0262-11-0	CONNECTOR 1/4 IN NPT X 1/4 TUBE PUSH	1.0	EA
19	168-0070-15-0	OPTIONAL HP "I" SERIES PANEL ASSEMBLY	2.0	EA

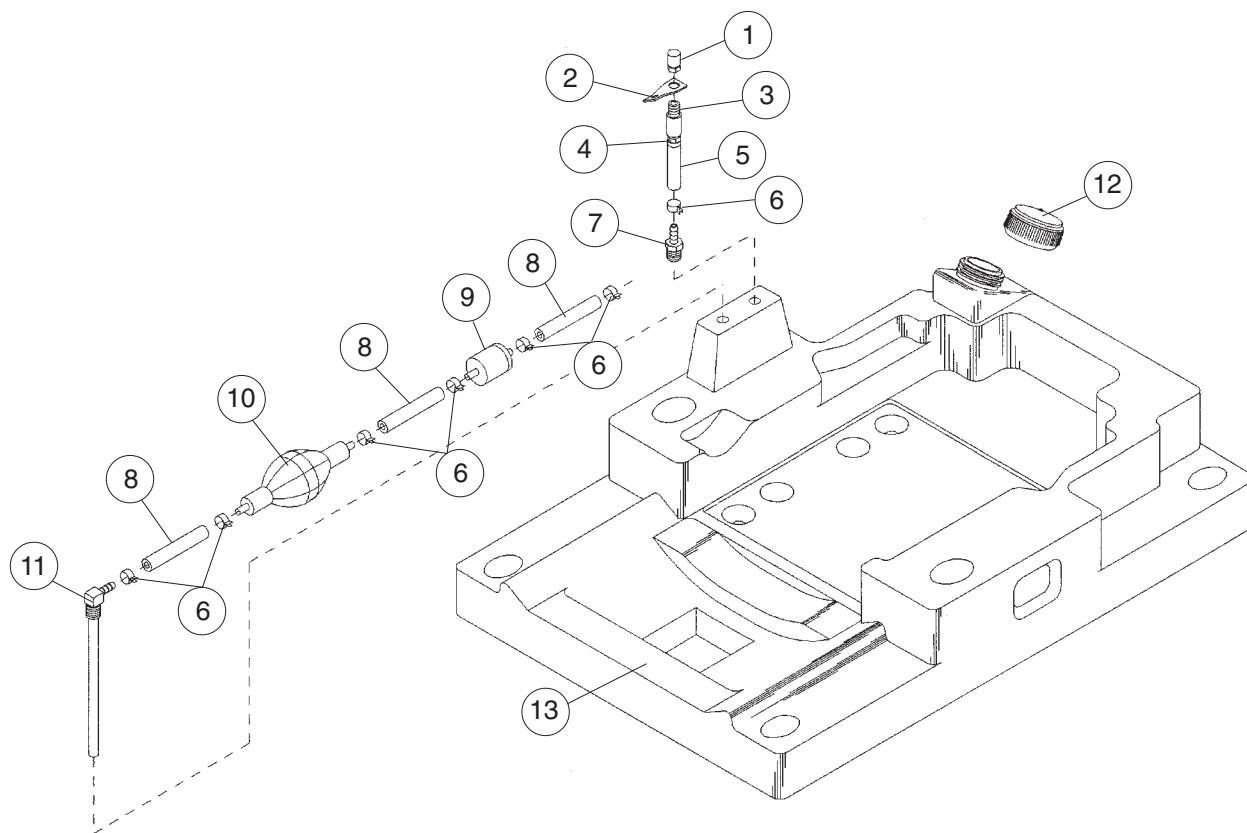

PL-10: FUEL VENT AND PICK-UP ASSEMBLY

ITEM	PART NUMBER	DESCRIPTION	QTY	UNIT
1	044-0260-02-0	1/8 AIR VENT-NO CHECK	1.0	EA
2	019-0560-06-0	FUEL VENT COUPLING BRACKET	1.0	EA
3	082-0110-00-0	COUPLING 1/8 NPT STEEL	1.0	EA
4	082-0118-02-0	ELBOW-1/8 NPT TO 1/4 ID HOSE	1.0	EA
5	340-0060-02-0	1/4 ID FUEL HOSE	1.9	FT
6	242-0620-01-0	HOSE/TUBING CLAMP	6.0	EA
7	082-0240-02-0	CONNECTOR-1/4MNPT X 1/4ID HOSE	1.0	EA
8	340-0060-02-0	1/4 ID FUEL HOSE	1.9	FT
9	BAS-493629	FUEL FILTER ASSEMBLY	1.0	EA
10	003-0080-00-0	PRIMING BULB WITH CLAMPS	1.0	EA
11	582-0220-05-0	FITTING-FUEL LINE PICK-UP	1.0	EA
12	008-0300-02-0	FUEL TANK CAP-2"	1.0	EA
13	108-0560-00-0	FUEL TANK PORTABLE PUMP	1.0	EA
14	108-0260-00-0	HP "I" SERIES FUEL TANK ASSEMBLY (NOT SHOWN)	1.0	EA

**HP SERIES
PORTABLE PUMPS**

USER OPERATION AND MAINTENANCE

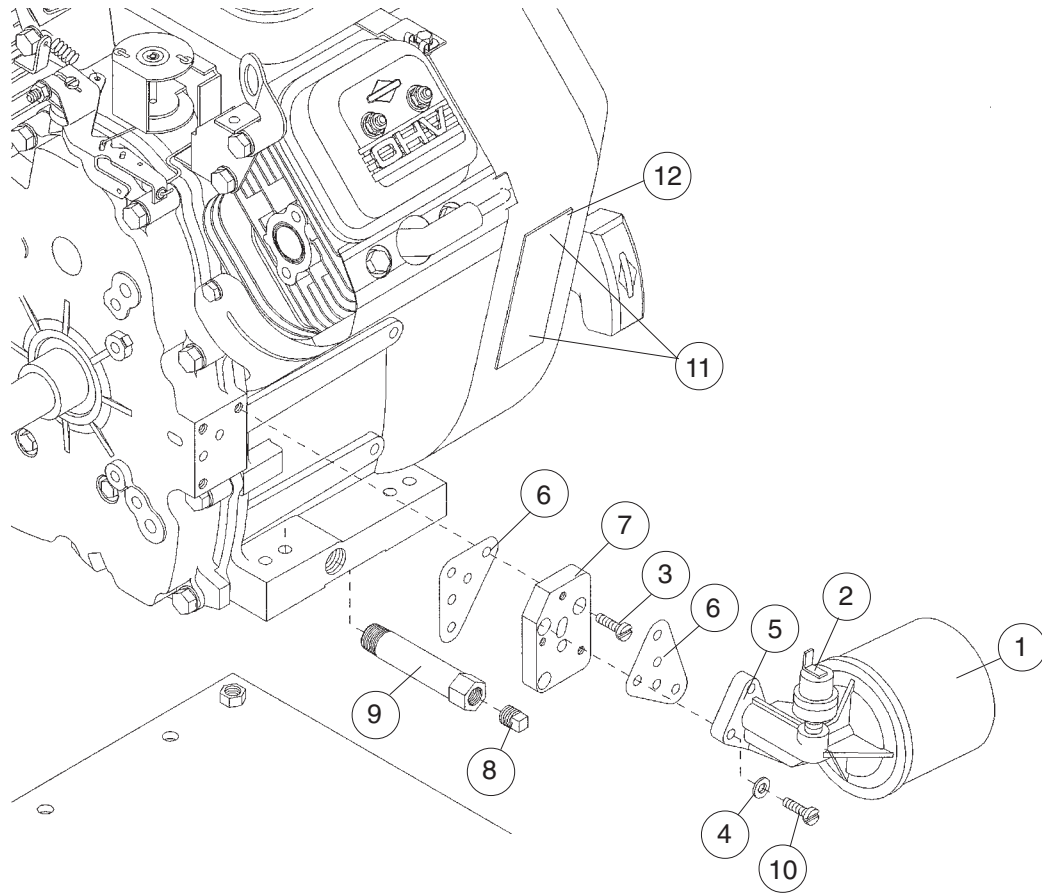

PL-11: OIL FILTER AND DRAIN ASSEMBLY

ITEM	PART NUMBER	DESCRIPTION	QTY	UNIT
1	BAS-491056	OIL FILTER	1.0	EA
2	BAS-491657	OIL PRESSURE SWITCH	1.0	EA
3	218-0608-19-0	SCREW M6-1 X 16 SOC. HD. SST LOCK	3.0	EA
4	BAS-805449	WASHER	3.0	EA
5	BAS-805292	OIL FILTER HOLDER	1.0	EA
6	046-6600-00-0	GASKET-HP SERIES OIL FILTER	2.0	EA
7	005-1150-00-0	OIL FILTER ADAPTER-HP SERIES	1.0	EA
8	217-0201-04-0	PLUG-1/4 NPT HEX SOCKET HD BRS	1.0	EA
9	082-0302-90-0	OIL DRAIN BUSHING	1.0	EA
10	BAS-805030	SCREW	3.0	EA
11	018-5002-00-0	DRIVE SCREW OR RIVET	2.0	EA
12	101-0500-00-0	SERIAL NUMBER PLATE	1.0	EA

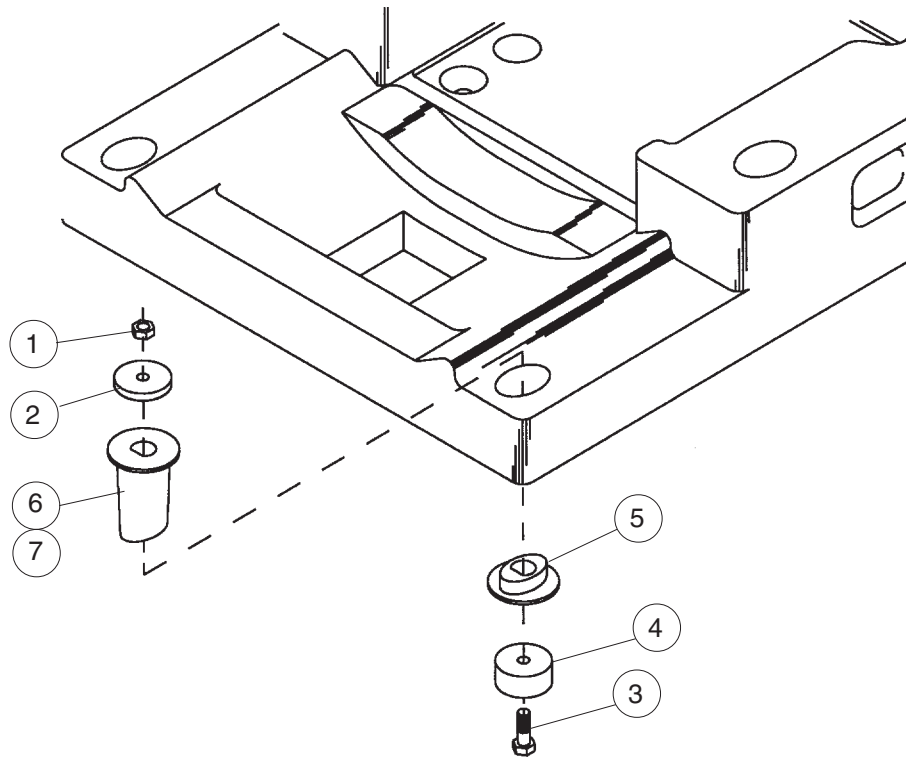

PL-12: HP "X" SERIES MOUNTING HARDWARE

ITEM	PART NUMBER	DESCRIPTION	QTY	UNIT
1	210-0805-11-0	NUT M8-1.25 STNLS STL LOCKING	12.0	EA
2	097-1850-00-0	WASHER 1.13 OD X 0.34 ID X 0.091 IN. THK ZINC PLTD STL	4.0	EA
3	218-0850-12-0	SCREW M8-1.25 X 100 H.H.ZINC PL	4.0	EA
4	097-0520-00-0	1-FZZ-264A RUBBER PAD #1019-2W	4.0	EA
5	048-1180-03-0	HANDLE SLEEVE BASE	4.0	EA
6	048-1180-01-0	HANDLE SLEEVE	4.0	EA
7	159-1350-00-0	SPACER	4.0	EA

