

TABLE OF CONTENTS

Introduction	3
Features / Specifications	3
Installation	3
Calibration	6
Low Pressure	6
High Pressure	8
Operation	8

Enfo II™ is a trademark of Class I, a subsidiary of Span Instruments, Inc.

Every effort has been made to supply complete and accurate information concerning the Enfo II's installation. However, Class I assumes no responsibility for the use of the Enfo II.

Copyright Class I, a subsidiary of Span Instruments, Inc., 607 N W 27th Avenue, Ocala, Florida 34475, USA

World rights reserved. No part of this publication may be stored in a retrieval system, transmitted, or reproduced in any way, including but not limited to photograph, magnetic or other record, without the prior agreement and written permission of Class I

Published in the United States of America; March 1995

INTRODUCTION

The CLASS I ENFO II Display provides a visual indication by means of digital display for engine RPM and battery voltage. The ENFO II Display also uses two sets of 10 LED bars to display oil pressure and engine temperature. The ENFO II System (Sensor Version) is made up of the following components:

- 1 display (Figures 1 and 2)

Note: The remote warning horn (1 Amp max) is supplied by the OEM/installer.

FEATURES / SPECIFICATIONS

- The compact packaging of the ENFO II conserves panel space.
- The ENFO II is quickly and simply installed.
- The ENFO II is easy to read because the displays use super bright LEDs.
- The ENFO II's Digital Tachometer displays readings in 50 RPM increments.
- Engine Temperature is an easy to read LED bar scale.
- Engine Oil Pressure is an easy to read LED bar scale.
- Power Requirement: 10.5 to 16 VDC (12-14 VDC recommended).
- Visual and audible warnings:

Low Oil Pressure (below 15 psi with engine running above 1000 RPM) — When engine oil pressure is low, the ENFO II warns the user by flashing the bars on the display and lighting the oil can symbol. The externally connected horn sounds in unison with the flashing display.

High Engine Temperature (above 230° F) — When engine temperature is high, the ENFO II warns the user by flashing the bars on the display and lighting the thermometer symbol. The externally connected horn sounds in unison with the flashing display.

Low Voltage (below 12 VDC for more than 30 seconds) — When the voltage is low, the ENFO II warns the user by alternately flashing the RPM and actual system voltage. The externally connected horn sounds in unison with the flashing display.

- Pressing the side button displays the system voltage. Releasing the button displays the RPM.
- Housing is die cast aluminum, waterproof, sealed and tested. *This makes the ENFO II excellent for outdoor service!*

ENFO II SYSTEM — SENSOR VERSION

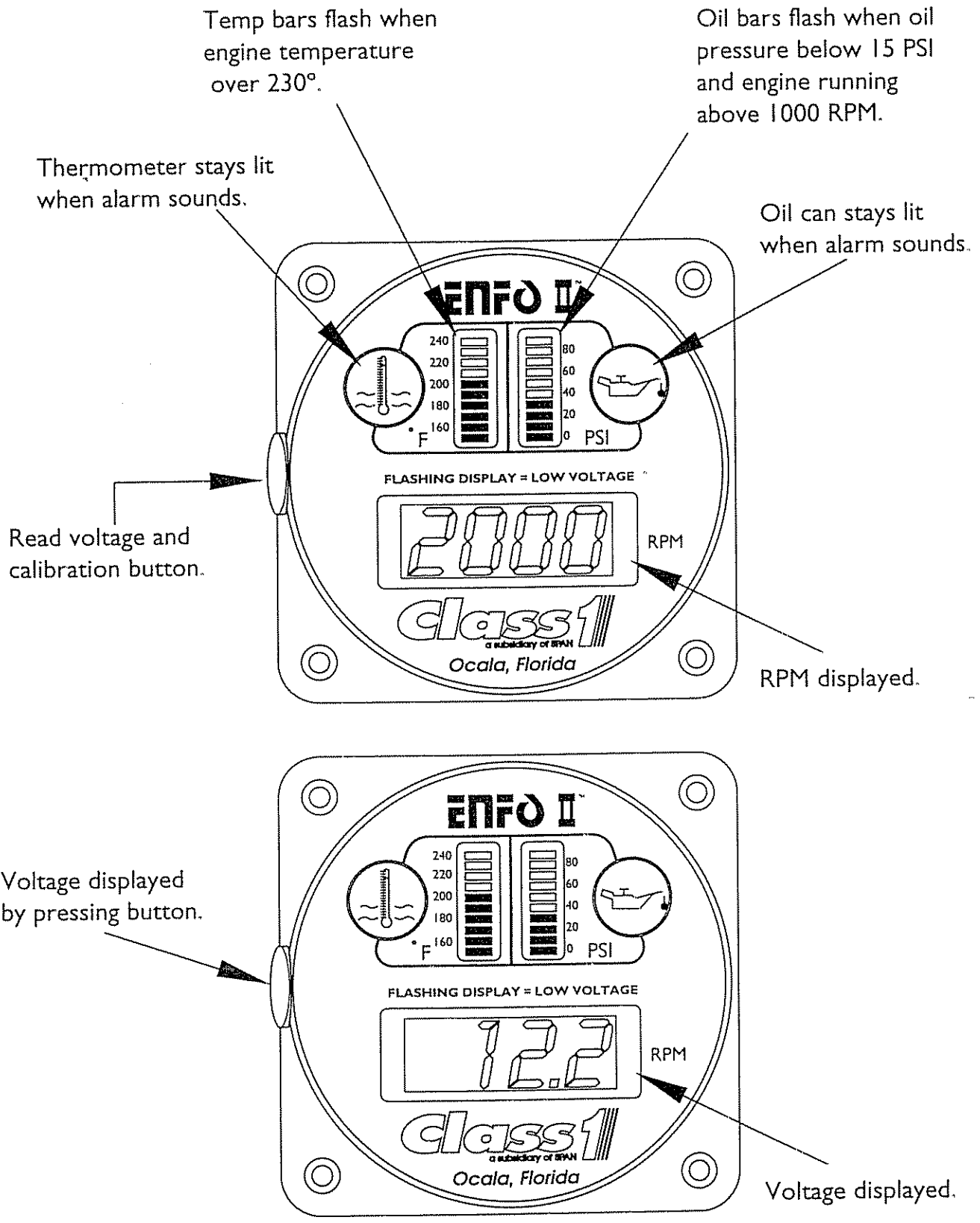

Figure 1. ENFO II Display

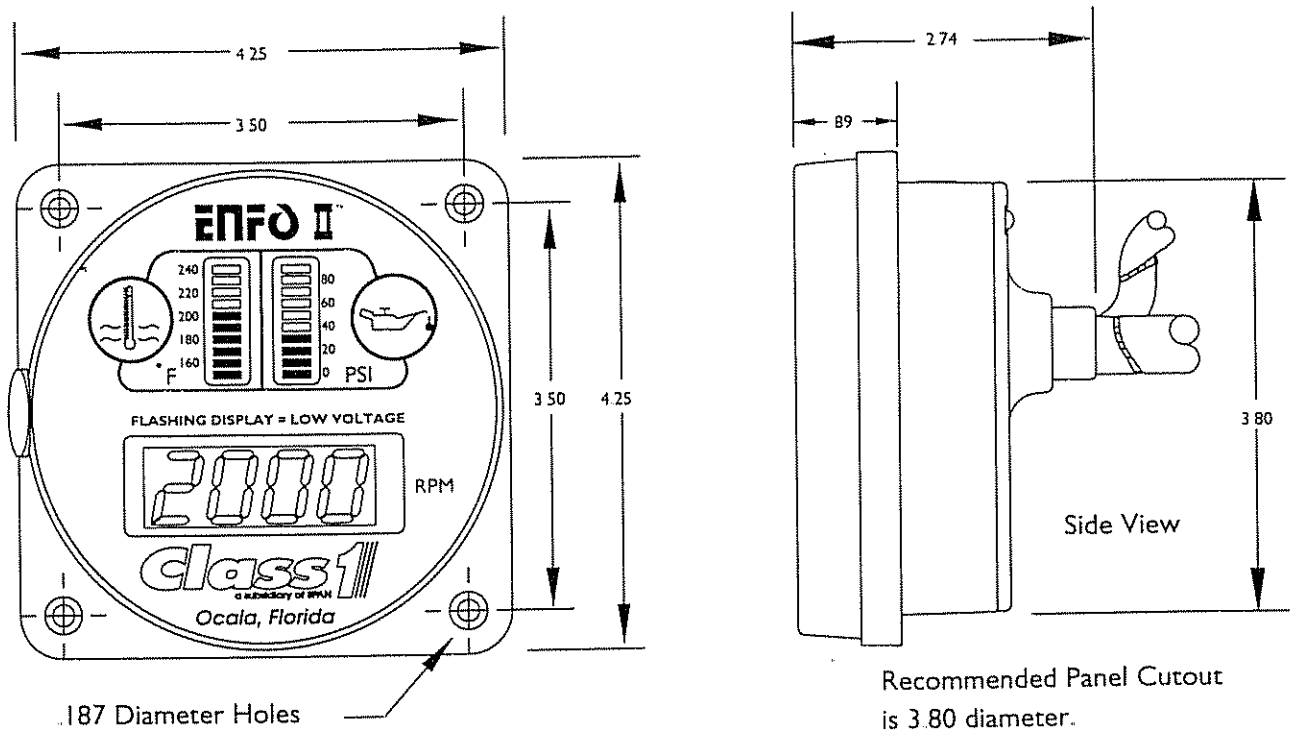

Figure 2. ENFO II Sensor Display Dimensions

INSTALLATION

Review these instructions in their entirety before installing the ENFO II System.

Use the dimensional and cut-out information provided in Figure 2 and install the components in the desired locations. Allow adequate space for cables that will be routed to each component. Figure 3 provides a wiring diagram for the ENFO II System.

OPERATION

Please read the following procedures before operating the ENFO II System.

Reading Voltage

Press side button (located on the left hand side of display) to read voltage. As long as side button is pressed, the display will read voltage. Release side button, the display will show voltage for 1 second and then return to RPM.

Reading Temperature

Under normal operation, the temperature display light (thermometer symbol) is off and the temperature bars show current engine temperature.

When temperature is 230° F and above, the temperature bars will flash on for 2 seconds then off for 6-8 seconds, the temperature display light stays lit, and a remote alarm/horn is activated.

Reading Oil Pressure

Under normal operation the oil pressure display light (oil can symbol) is off and the oil pressure bars show current oil pressure.

When oil pressure is below 15 psi and engine is running above 1000 RPM, the temperature bars will flash on for 2 seconds then off for 6-8 seconds, the oil pressure display light stays lit, and a remote alarm/horn is activated.

Reading RPM

Under normal operation the RPM display shows current engine RPM. The RPM resolution is ± 50 RPM. Exceeding 4200 RPM will cause the display to read HI.

Battery Alarm

If battery voltage drops below 12 volts for 30 seconds or more, the display flashes between actual voltage and RPM. A "low voltage" alarm sounds for 2 seconds and off for 6-8 seconds.

Calibration

The only calibration required for the ENFO II Display is setting the RPM, as follows:

1. Set the engine to 1200 RPM.
2. Remove power from the ENFO II Display.
3. Press and continue to hold button and apply power to ENFO II Display.
4. When display reads **CAL**, release the button.
5. Check to see if engine is still running at 1200 RPM. Push and release the button.
6. Display now reads **HOLD**. The ENFO II Display proceeds through a self test and the display will read 1200 RPM. This should take approximately 10-60 seconds from the time the button is pressed.

Note: When the display reads HOLD, do not push the button.

Right tail 101099

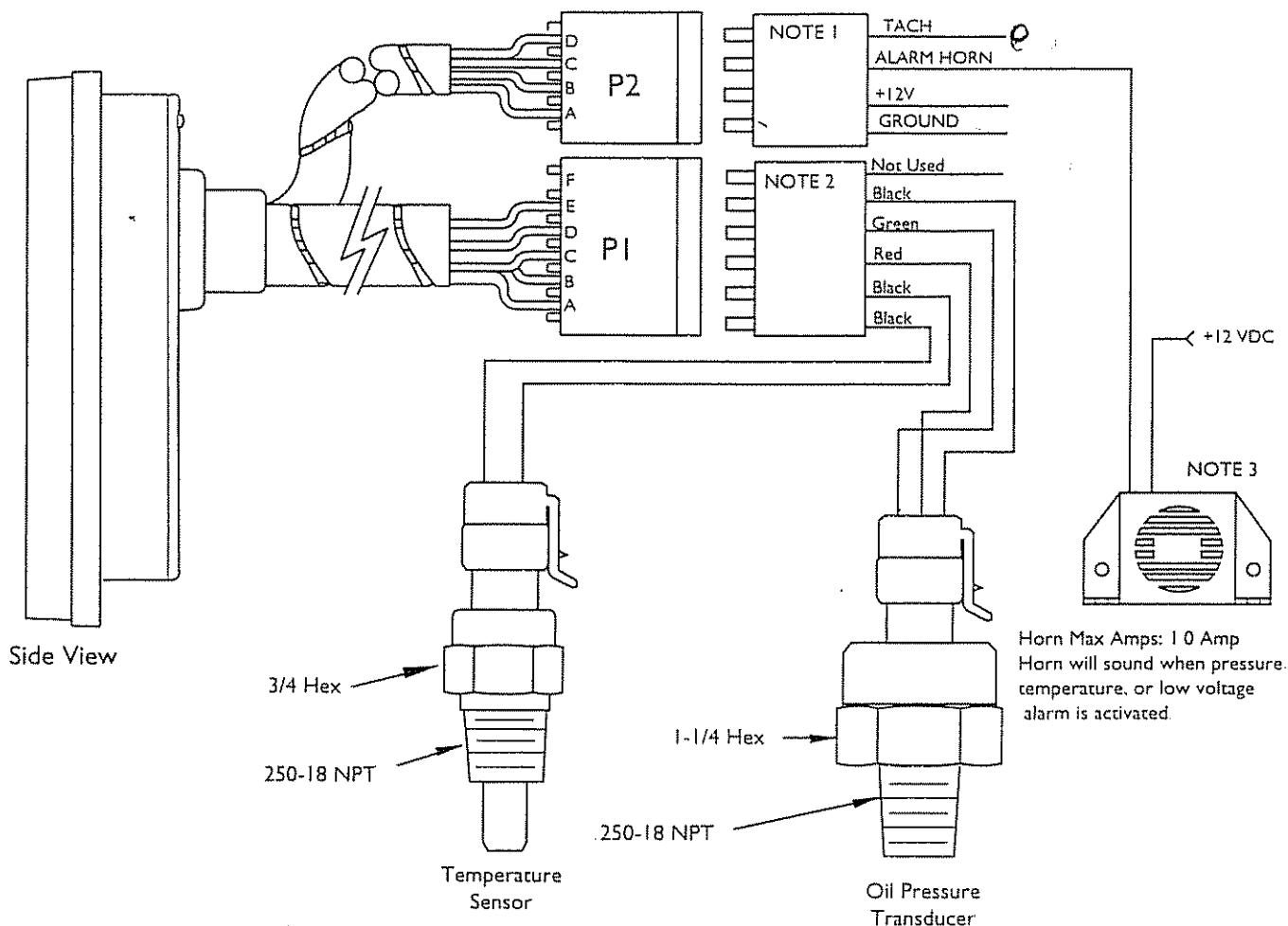

WIRE LIST

FROM LOCATION	WIRE COLOR (P1 & P2)	SIGNAL NAME
P1-A	YELLOW	+TEMP SENSOR
P1-B	ORANGE	-TEMP SENSOR
P1-C	RED/WHITE	OIL PRESSURE +5V B
P1-D	GREEN	OIL PRESSURE -SIG C
P1-E	BLK/WHITE	OIL PRESSURE (-) A
P2-A	BLACK	GROUND
P2-B (NOTE 4)	RED	+BATTERY 12V
P2-C	BROWN	ALARM HORN
P2-D	BLUE	TACHOMETER GENERATOR OR ALTERNATOR

NOTE 1: *socket 12089188*
Packard casing 12015797, pins 12034051, and seals 12034365
12015899

NOTE 2: Packard casing 12015799, pins 12034365, and seals 12034365

NOTE 3: Horn provided by installer.

NOTE 4: Connect this lead to the battery or as close as possible. (For accurate battery voltage readings)

Figure 3. ENFO II Wiring Diagram

*9 2802184
2802820 OP Sensor
2802821 Temp Sensor*