

Name	Four Output Tank Level	Engineering Standard Number C1-105593
Identifier	OEM Installation and Calibration	

This document addresses the *Class 1* Tank Level Gauge with four outputs and the installation, calibration and operation of this unit.

The module has four (4) positive (12 VDC) outputs capable of sourcing 7.5 Amperes each.

Output indications with tank level decreasing:

	Full Light	3/4 Light	1/2 Light	1/4 Light
Full to 7/8 tank	ON	ON	ON	ON
13/16 to 3/4 tank	Flash	ON	ON	ON
3/4 to 5/8 tank	OFF	ON	ON	ON
9/16 to 1/2 tank	OFF	Flash	ON	ON
1/2 to 3/8 tank	OFF	OFF	ON	ON
5/16 to 1/4 tank	OFF	OFF	Flash	ON
1/4 and below	OFF	OFF	OFF	Flash

Output indications with tank level increasing:

	Full Light	3/4 Light	1/2 Light	1/4 Light
1/8 and below	OFF	OFF	OFF	Flash
3/8 to 1/4 tank	OFF	OFF	Flash	ON
1/2 to 3/8 tank	OFF	OFF	ON	ON
5/8 to 1/2 tank	OFF	Flash	ON	ON
3/4 to 5/8 tank	OFF	ON	ON	ON
7/8 to 3/4 tank	Flash	ON	ON	ON
Full to 7/8 tank	ON	ON	ON	ON

Fault Indications:

- 1/4 and Full lights alternately flashing and COM LED flashing
Invalid calibration (recalibrate system)
- 1/4 and 1/2 lights rapidly counter flashing and COM LED flashing
Transducer Fault (check wiring and transducer)
- 3/4 and Full lights rapidly counter flashing and COM LED flashing
Transducer shorted to 5 volts (check wiring and transducer)
- 1/2 and 3/4 lights rapidly counter flashing and COM LED flashing
System Fault (repower system, if problem repeats, recalibrate unit and if the error is not resolved, replace display)

Name	Four Output Tank Level	Engineering Standard Number C1-105593
Identifier	OEM Installation and Calibration	

Tank Level Gauge
Transducer Installation

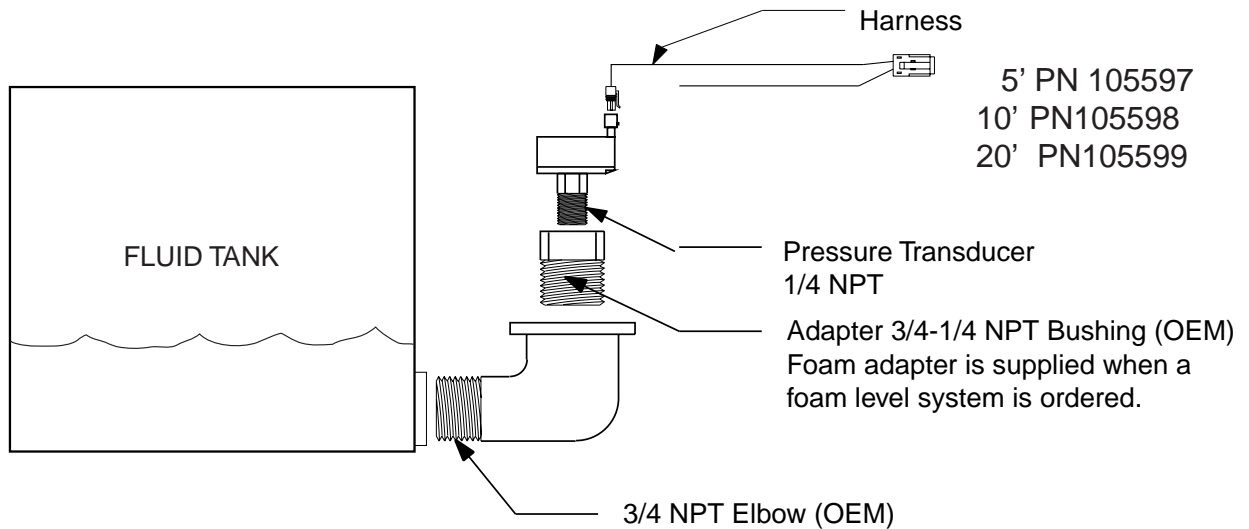

The transducer must be mounted vertically as depicted to insure an accurate and reliable reading. This will also prevent damage to the transducer from freezing. Harnesses are supplied with a cable to connect the transducer. Loose wires with appropriate terminals for the outputs and ground are including to facilitate installation.

The transducer measures the column of water in the tank above the opening of the elbow. When calibrating for a full tank it is important that the tank not be overfilled. If the fill opening or tank vent is above the transducer, care should be taken not to have water in this area when calibrating the tank level gauge. The transducer should never be mounted in the sump area because of sludge and potential inaccuracies in calibration.

Mount a 3/4 NPT elbow just off the bottom of the tank, enough to keep sediment out of the elbow and transducer (**PN 102162**). Attach a 3/4 to 1/4 NPT adapter (supplied for foam) to the elbow and mount the transducer to that. The elbow and adapter need to be installed so that the transducer is mounted vertically.

Name	Four Output Tank Level	Engineering Standard Number C1-105593
Identifier	OEM Installation and Calibration	

The module is waterproof and can be mounted in almost any location. Avoid areas of Extremely high temperature (above 75 deg C) and/or high vibration.

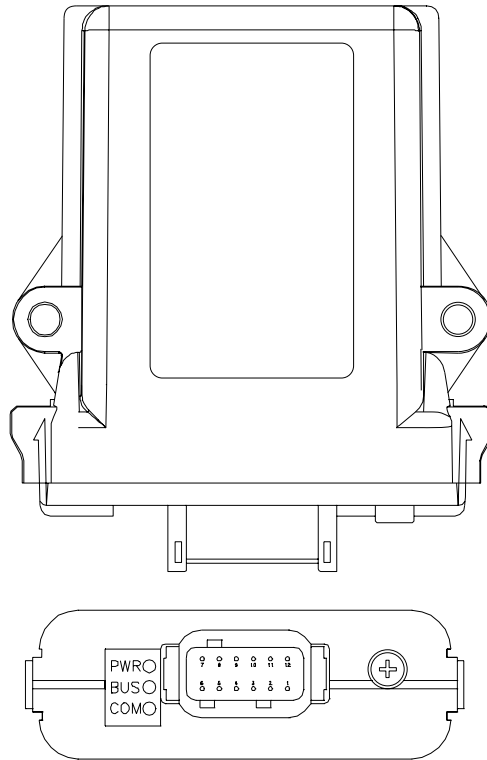

Connector	Connector information:	Lock
Deutsch DTM06-12SA	Terminal	WM-12S
	0462-201-20141(18-24 Ga.)	
	1062-20-0122 (10-16 Ga.)	

1	1/4 indication output	7	NC
2	NC	8	Transducer +5 VDC output
3	NC	9	Full indication output
4	3/4 indication output	10	1/2 indication output
5	Transducer Signal input	11	Transducer Ground output
6	NC	12	Ground
	#10 Ring terminal		Output Driver Power

LED Status

Red	PWR	System Power and Ground OK
Amber	BUS	Driver Power OK
Green	COM	Flashes 8X on power up and then steady

Name	Four Output Tank Level	Engineering Standard Number C1-105593
Identifier	OEM Installation and Calibration	

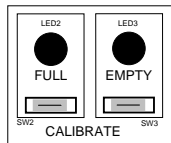
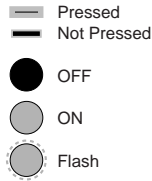

Press and hold both switches for two (2) seconds. Both LED's will illuminate.

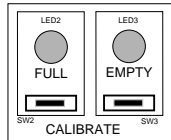

Release both switches. Both LED's will Flash at the same time.

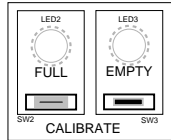

Press the switch for the calibration you will perform first. (Full or Empty) You can start with either, this example will use FULL.

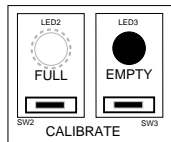

The FULL LED will start to flash rapidly. The EMPTY LED should turn off.

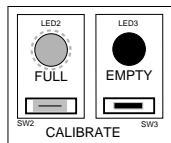

With the tank filled, press the FULL calibration switch for 1/2 second.

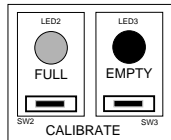

The FULL LED will turn on steady for 1/2 second and then turn off. The EMPTY LED will start flashing at a rate of once per second.

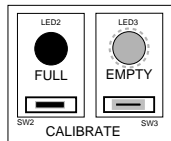

Press the EMPTY switch. The flash rate will increase.

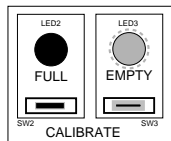

Empty the tank and then press the EMPTY switch again.

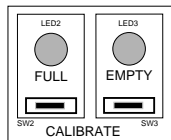

The EMPTY LED will come on steady for 1/2 second and then both LED's will turn on steady and then turn off. The outputs will indicate the current tank level. Level Calibration is complete.

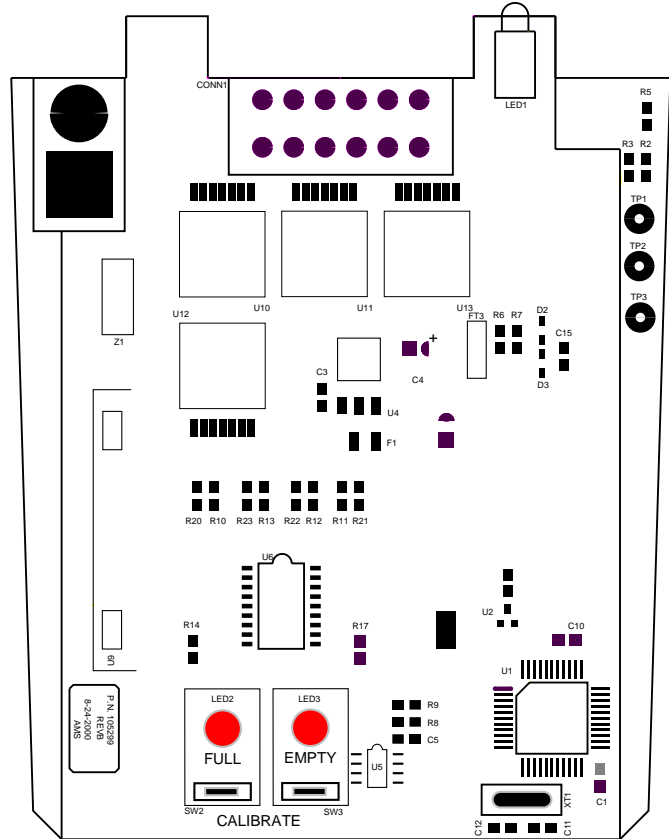

Level Calibration

For Level Calibration, enter the following password

EMPTY EMPTY EMPTY EMPTY EMPTY FULL EMPTY FULL

Press and hold both calibration switches for two (2) seconds. Both calibration LED's will illuminate.

Release both switches. Both calibration LED's will flash as well as the Full output and the 1/4 tank output.

With the tank either empty or full, press the switch associated with the condition of the tank (empty or full) that you are calibrating. The LED, Output and the COM LED will come on for 1/2 second and then go out.

The opposite calibration LED, output and the COM LED will flash at a rate of once per second.

Press the switch associated with the flashing calibration LED. The flash rate will increase.

Either empty or fill the tank as appropriate. Allow the water level to stabilize and then press the calibration switch under the flashing LED. (hold for 1/2 second) Both calibration LED's will come on steady, The outputs will indicate the current tank level and the COM LED will return to a steady green.

Name	Four Output Tank Level	Engineering Standard Number C1-105593
Identifier	OEM Installation and Calibration	

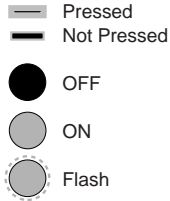

Volume Calibration

For Volume Calibration, enter the following password **EMPTY FULL EMPTY FULL EMPTY EMPTY EMPTY**

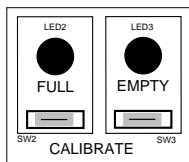

Press and hold both switches for two seconds. Both LED's will illuminate.

The COM LED will turn off.

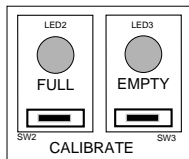

Release both switches. Both LED's will be on steady. Ensure that the tank is full.

The COM LED will flash. The Full and 1/4 outputs will be steady ON.

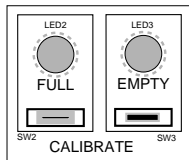

Press the full switch and hold until the EMPTY LED turns OFF. You can start with either an empty or a full tank. This example uses the a full tank to start with. The FULL value has been stored

The COM LED will be flashing rapidly. The first volume point is now stored. The output for the 3/4 calibration point will turn ON.

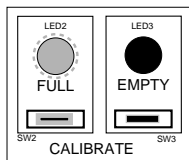

The FULL LED will be flashing rapidly. Drain the tank to the 3/4 full mark Press and hold the FULL switch until the EMPTY LED turns ON. The 3/4 value has been stored.

The current tank level is stored and associated with 3/4 full level.

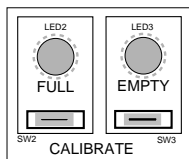

Both LED's are now flashing slowly. Drain the tank to the 1/2 full level. Press and hold both switches until the FULL LED turns OFF. The 1/2 tank value has been stored.

The 1/2 tank output will turn on and the COM LED will flash slowly. The current tank level is stored and associated with half tank volume.

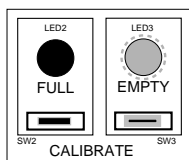

The empty LED will be slowly flashing. Drain the tank to the 1/4 level. Press and hold the EMPTY switch until the FULL LED turns ON. The 1/4 tank value has been stored.

The output for the 1/4 tank calibration point will turn on and the COM LED will continue flashing at the slow rate. The 1/4 tank value is stored.

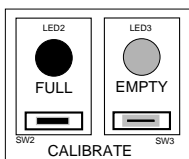

The EMPTY LED will be flashing rapidly. Press the EMPTY switch until the LED stops flashing. The calibration procedure is complete. Both LED's should be OFF.

The COM LED will flash quickly. Empty the tank the 1/4 output will be flashing rapidly. Press and hold the switch under the EMPTY LED until it remains steady. The current transducer value is stored and associated with empty. Outputs will now indicate the current tank level and the COM LED will be steady.