



Class 1

ISO 9001 CERTIFIED

607 NW 27th Ave
Ocala, FL 34475
Phone: (352) 629-5020 or 800-533-3569
Fax: (352)-629-2902

SUITABLE FOR EXTERNAL DISTRIBUTION

OPERATION MANUAL

Intelli-Tank Level 40

ITL
40



 607 NW 27th Ave Ocala, FL 34475 Ph: 352-629-5020 or 1-800-533-3569 Fax: 352-629-2902 or 1-800-520-3473	SUITABLE FOR EXTERNAL DISTRIBUTION			PAGE	1 of 25
	OPERATION MANUAL			DATE	9/24/2008
PRODUCT GROUP	ITL40	P/N	118404-XX	REV	1.00
PRODUCT	Intelli-Tank Level 40			BY	AMS

1.	REVISION LOG	3
2.	SYSTEM OVERVIEW	4
2.1.	SCOPE	4
2.2.	PART NUMBERS.....	4
2.3.	MODES OF OPERATION.....	4
3.	OPERATION	5
3.1.	LED INDICATIONS.....	5
3.1.1.	<i>Initial power ON indications</i>	5
3.1.2.	<i>Level indications</i>	5
3.1.3.	<i>Error indications</i>	6
3.2.	MAGNETIC SWITCHES	7
3.3.	CALIBRATION	8
3.3.1.	<i>1 Point Calibration</i>	8
3.3.2.	<i>2 Point Calibration (empty then full)</i>	8
3.3.3.	<i>2 Point Calibration (full then empty)</i>	8
3.3.4.	<i>5 Point Calibration</i>	9
3.3.5.	<i>9 Point Calibration</i>	9
3.3.6.	<i>Calibration retention</i>	9
3.3.7.	<i>Invalid calibration</i>	9
3.3.8.	<i>Calibration incomplete</i>	10
3.4.	SELF TEST	10
3.5.	SETTING THE DIM LED LEVEL.....	10
3.6.	SHOW SOFTWARE VERSION, DEVICE SETTINGS, AND ERRORS	10
3.7.	CONFIGURE THE COMMUNICATION METHOD	11
3.7.1.	<i>Configuring a display as a Master with 1-wire communications</i>	11
3.7.2.	<i>Configuring a display as a Remote with 1-wire communications</i>	11
3.7.3.	<i>Configuring a display as a Master with CAN communications</i>	11
3.7.4.	<i>Configuring a display as a Remote with CAN communications</i>	11
3.8.	CONFIGURE A CUSTOM MESSAGE SCROLL.....	12
3.9.	USE THE DISPLAY REFERENCE MARK	12
3.10.	SLOSH DAMPENING FEATURE	13
4.	PASSWORD LIST	14
5.	INSTALLATION	15
5.1.	CUTOUT DIMENSIONS	15
5.2.	OUTER BEZEL DIMENSIONS	15
5.3.	LABEL ORIENTATION	16
5.4.	PRESSURE SENSOR.....	16
5.4.1.	<i>Approved fluids</i>	16
6.	WIRING	17
6.1.	ITL40 CONNECTOR	17
6.2.	PRESSURE SENSOR CONNECTOR	17
6.3.	COMMUNICATION WIRING EXAMPLES	18
6.3.1.	<i>1-wire method, 1 MASTER and 2 REMOTES</i>	18
6.3.2.	<i>1-wire method, 2 MASTERS and 2 REMOTES</i>	18
6.3.3.	<i>CAN method, 1 MASTER and 2 REMOTES</i>	19
6.3.4.	<i>CAN method, 2 MASTERS and 2 REMOTES</i>	19
6.3.5.	<i>Terminating resistor requirement (CAN communication)</i>	20

 607 NW 27th Ave Ocala, FL 34475 Ph: 352-629-5020 or 1-800-533-3569 Fax : 352-629-2902 or 1-800-520-3473	SUITABLE FOR EXTERNAL DISTRIBUTION			PAGE	2 of 25	
	OPERATION MANUAL				DATE	9/24/2008
	PRODUCT GROUP	ITL40	P/N	118404-XX	REV	1.00
	PRODUCT	Intelli-Tank Level 40			BY	AMS

6.4.	COMMUNICATION COMPATIBILITY WITH CLASS 1 PRODUCTS.....	20
6.4.1.	1-wire compatibility.....	20
6.4.2.	CAN compatibility.....	20
7.	TROUBLESHOOTING.....	21
7.1.	EVALUATION TABLE	21
7.2.	USING THE DISPLAY TO VERIFY PRESSURE SENSOR SIGNAL VOLTAGE	22
8.	GLOSSARY	23
9.	TECHNICAL DETAILS	24
9.1.	TECHNICAL DETAILS	24
9.2.	WEEE (WASTE OF ELECTRICAL AND ELECTRONIC EQUIPMENT) DIRECTIVE.....	24
9.3.	CE STATEMENT	24
10.	板料信息声明 (ROHS 声明) – DECLARATION INFORMATION SHEET (ROHS DECLARATION)	25
10.1.	产品中有毒和有害的物质或成份的名称和含量 – (NAMES AND CONTENTS OF THE TOXIC AND HAZARDOUS SUBSTANCES OR ELEMENTS IN THE PRODUCTS)	25

 607 NW 27th Ave Ocala, FL 34475 Ph: 352-629-5020 or 1-800-533-3569 Fax: 352-629-2902 or 1-800-520-3473	SUITABLE FOR EXTERNAL DISTRIBUTION OPERATION MANUAL			PAGE	3 of 25	
				DATE	9/24/2008	
	PRODUCT GROUP	ITL40	P/N	118404-XX	REV	1.00
	PRODUCT	Intelli-Tank Level 40			BY	AMS

1. Revision Log

Rev	Date	Approved	Changes
1.00	9-24-2008	AGK	Initial requirements

 607 NW 27th Ave Ocala, FL 34475 Ph: 352-629-5020 or 1-800-533-3569 Fax: 352-629-2902 or 1-800-520-3473	SUITABLE FOR EXTERNAL DISTRIBUTION			PAGE	4 of 25	
	OPERATION MANUAL				DATE	9/24/2008
	PRODUCT GROUP	ITL40	P/N	118404-XX	REV	1.00
	PRODUCT	Intelli-Tank Level 40			BY	AMS

2. System Overview

2.1. Scope

The Intelli-Tank Level 40 (ITL40) is designed to display a liquid's volume to an eighth of a tank level accuracy through 180-degree viewable ultra-bright LEDs. An Intelli-Tank Level 40 set as a MASTER uses a 0-5 PSI (0-34.47 kPa, 0-0.3447 bar) pressure sensor to obtain tank level information and then relays that information along the communication line(s) (1-Wire or CAN) to ITL40's set as REMOTES. Multiple REMOTE units can be linked to the MASTER tank level.

2.2. Part numbers

Tank Level Gauge	C1 – p/n 118404-01 – Red LEDs p/n 118404-02 – Amber LEDs p/n 118404-03 – Yellow LEDs p/n 118404-04 – Green LEDs p/n 118404-05 – Blue LEDs p/n 118404-06 – 2 Red, 2 Yellow, 2 Blue, 2 Green rows of LEDs
Labels	C1 – p/n 117691 – water (blue) p/n 117692 – foam (red) p/n 117693 – foam (green)
Pressure Sensor	C1 – p/n 102162 – 0 to 5 PSI (0 to 34.47 kPa, 0 to 0.3447 bar) gage
Adapter bushing	C1 – p/n 102219 – ¾ to ¼ NPT
Installation Harness	C1 – p/n 118485-10 – Master display, 10 feet p/n 118485-20 – Master display, 20 feet p/n 118485-30 – Master display, 30 feet p/n 118485-40 – Master display, 40 feet p/n 118695 – Remote display
Terminating resistor (CAN)	C1 – p/n DT06-3S-P006
“Y” connector (CAN)	C1 – p/n DT04-3P-P007
Operation Manual	C1 – p/n 118253
One Page Manual	C1 – p/n 118252

2.3. Modes of Operation

Master When the ITL40 display is calibrated with a proper pressure signal it automatically becomes a MASTER display and will send tank level information along the communication line(s) (either 1-wire or CAN) to all other REMOTE displays.

Remote ITL40 displays are initially shipped as REMOTE displays. A REMOTE display only requires power, ground and communications line(s) (either 1-wire or CAN). The REMOTE display mimics the MASTER display's LEDs by reading the appropriate information on the communication line(s).

 607 NW 27th Ave Ocala, FL 34475 Ph: 352-629-5020 or 1-800-533-3569 Fax: 352-629-2902 or 1-800-520-3473	SUITABLE FOR EXTERNAL DISTRIBUTION		PAGE	5 of 25	
	OPERATION MANUAL		DATE	9/24/2008	
PRODUCT GROUP	ITL40	P/N	118404-XX	REV	1.00
PRODUCT	Intelli-Tank Level 40		BY	AMS	

3. Operation

3.1. LED indications

The ITL40 display uses 8 rows of LEDs to show the unit status, tank level indication (section 3.1.2), and error indications (section 3.1.3).

3.1.1. Initial power ON indications

When the ITL40 is first powered up the display will...



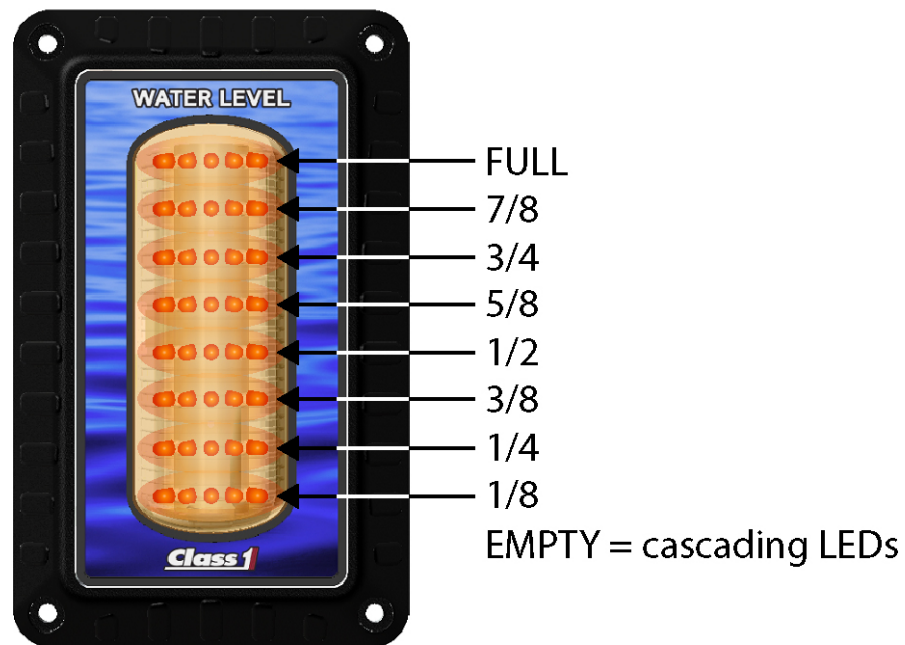

1. Turn ON all of the LEDs then immediately cycle OFF each LED starting at the top row.
2. Display the custom scroll greeting (default is "CLASS 1", but can be custom configured – section 3.8).
3. The LEDs will show the tank level indication (section 3.1.2) or error indication (section 3.1.3).

3.1.2. Level indications

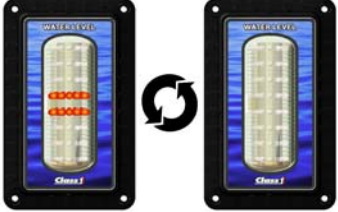

 607 NW 27th Ave Ocala, FL 34475 Ph: 352-629-5020 or 1-800-533-3569 Fax: 352-629-2902 or 1-800-520-3473	SUITABLE FOR EXTERNAL DISTRIBUTION <h2 style="text-align: center;">OPERATION MANUAL</h2>			PAGE 6 of 25
	PRODUCT GROUP ITL40	P/N 118404-XX	DATE 9/24/2008	REV 1.00
PRODUCT Intelli-Tank Level 40			BY AMS	

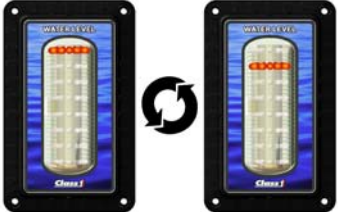
3.1.3. Error indications

Condition	Visual
Invalid calibration	
Incomplete calibration	
EEPROM error	
Sensor signal voltage above 4.8V	
Sensor signal voltage below 0.4V	

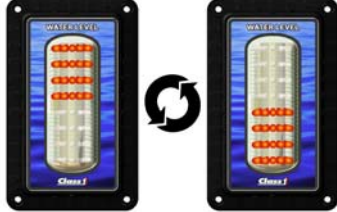
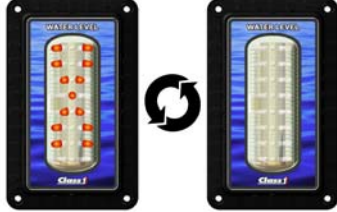
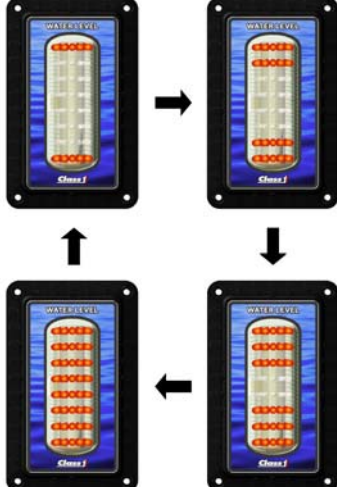
Condition	Visual
"NO DATA" REMOTE is not receiving data from MASTER	
Password Error ⁽¹⁾	
Unit type error ⁽²⁾ The display is not configured as a MASTER or REMOTE	

⁽¹⁾ "X" flashed four times.

⁽²⁾ Indicates that the unit type has erroneously changed. The two valid unit types are REMOTE and MASTER.

 607 NW 27th Ave Ocala, FL 34475 Ph: 352-629-5020 or 1-800-533-3569 Fax: 352-629-2902 or 1-800-520-3473	SUITABLE FOR EXTERNAL DISTRIBUTION OPERATION MANUAL		PAGE 7 of 25
	PRODUCT GROUP ITL40	P/N 118404-XX	DATE 9/24/2008
	PRODUCT Intelli-Tank Level 40		REV 1.00 BY AMS

3.2. Magnetic switches

The ITL40 has two magnetic switches (left and right). The switches are activated by touching a magnet to either side of the display in the areas shown in picture below. The label has a small “o” to indicate the location of the magnetic switch.



For best results the magnet should be positioned over the desired switch approximately 2 inches from the front of the display, pushed directly to the front of the display, and then pulled back to the start position (do not use a swiping motion).

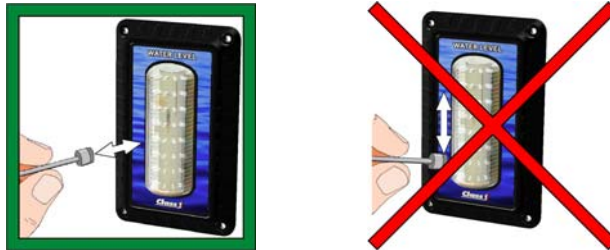

The LEDs on the display will indicate which switch was activated for approximately half a second and then the display will go blank (LEFT = left two columns of LEDs, RIGHT = right two columns of LEDs).



LEFT (L) indication



RIGHT (R) indication

The maximum time between magnetic switch activations is two seconds. If longer than two seconds have passed between activations the unit will resume normal operation and the password attempted will be cleared.

 607 NW 27th Ave Ocala, FL 34475 Ph: 352-629-5020 or 1-800-533-3569 Fax: 352-629-2902 or 1-800-520-3473	SUITABLE FOR EXTERNAL DISTRIBUTION			PAGE	8 of 25	
	OPERATION MANUAL				DATE	9/24/2008
	PRODUCT GROUP	ITL40	P/N	118404-XX	REV	1.00
	PRODUCT	Intelli-Tank Level 40			BY	AMS

3.3. Calibration

The ITL40 display can be calibrated five different ways: 1-point (quick calibration), 2-point (level calibration) empty then full, 2-point (level calibration) full then empty, 5-point and 9-point (volume calibration).

To enter calibration mode use a magnet and activate the magnetic switches in the order of the appropriate password.

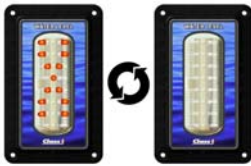

Entering an invalid password will initiate a “password error” pattern on the display (“X” flashed four times). The unit will then resume its normal operation and the user can attempt to re-enter the password.

Calibrate the unit by entering the desired point calibration password –

1 point	RLLR LRRL (see section 3.3.1)
2 point (empty then full)	RLLR LLRL (see section 3.3.2)
2 point (full then empty)	RLLR LRRR (see section 3.3.3)
5 point (start at empty)	RLLR LRLR (see section 3.3.4)
9 point (start at empty)	RLLR RLLR (see section 3.3.5)

During calibration, the process can be cancelled at any time by activating the **LEFT** magnetic switch. This will allow the display to exit without showing an “incomplete calibration error” (section 3.1.3) on the next power cycle.

3.3.1. 1 Point Calibration

1 point calibration only calibrates the full point. The empty calibration is always set to 0.55V (approximately 1.5 inches of liquid).

1. Make certain that the tank is **FULL**.
2. Enter the password **RLLR LRRL**. The display will respond by showing the number “1”. The display will then start normal operation with the new calibration by displaying **FULL** (all LEDs on).

3.3.2. 2 Point Calibration (empty then full)

1. Enter the password **RLLR LLRL**. The display will respond by showing the number “2”. The display will then begin scrolling the text “SET EMPTY” across the display.
2. Make certain that the tank is **EMPTY** and then activate the **RIGHT** switch to store that point. The display will flash the top two LED rows and then begin scrolling the text “SET FULL”.
3. Fill the tank and then activate the **RIGHT** switch. The display will respond by flashing the top two LED rows and then start normal operation with the new calibration by displaying **FULL** (all LEDs on).

3.3.3. 2 Point Calibration (full then empty)

1. Enter the password **RLLR LRRR**. The display will respond by showing the number “2”. The display will then begin scrolling the text “SET FULL” across the display.
2. Make certain that the tank is **FULL** and then activate the **RIGHT** switch to store that point. The display will flash the top two LED rows and then begin scrolling the text “SET EMPTY”.
3. Drain the tank and then activate the **RIGHT** switch. The display will respond by flashing the top two LED rows and then start normal operation with the new calibration by displaying **EMPTY** (cascading LEDs).

 607 NW 27th Ave Ocala, FL 34475 Ph: 352-629-5020 or 1-800-533-3569 Fax: 352-629-2902 or 1-800-520-3473	SUITABLE FOR EXTERNAL DISTRIBUTION			PAGE	9 of 25	
	OPERATION MANUAL				DATE	9/24/2008
	PRODUCT GROUP	ITL40	P/N	118404-XX	REV	1.00
	PRODUCT	Intelli-Tank Level 40			BY	AMS

3.3.4. 5 Point Calibration

1. Enter the password **RLLR LRLR**. The display will respond by showing the number "5". The display will then begin scrolling the text "SET EMPTY".
2. Make certain that the tank is EMPTY and then activate the **RIGHT** switch to store that point. The display will flash the top two LED rows and then begin scrolling the text "SET 1/4".
3. Fill the tank to the one-quarter tank point and then activate the **RIGHT** switch. The display will flash the top two LED rows and then begin scrolling the text "SET 1/2".
4. Fill the tank to the one-half tank point and then activate the **RIGHT** switch. The display will flash the top two LED rows and then begin scrolling the text "SET 3/4".
5. Fill the tank to the three-quarter tank point and then activate the **RIGHT** switch. The display will flash the top two LED rows and then begin scrolling the text "SET FULL".
6. Fill the tank to the full point and then activate the **RIGHT** switch. The display will respond by flashing the top two LED rows and then start normal operation with the new calibration by displaying FULL (all LEDs on).

3.3.5. 9 Point Calibration

1. Enter the password **RLLR RLLR**. The display will respond by showing the number "9". The display will then begin scrolling the text "SET EMPTY".
2. Make certain that the tank is EMPTY and then activate the **RIGHT** switch to store that point. The display will flash the top two LED rows and then begin scrolling the text "SET 1/8".
3. Fill the tank to the one-eighth point and then activate the **RIGHT** switch. The display will flash the top two LED rows and then begin scrolling the text "SET 1/4".
4. Fill the tank to the one-quarter point and then activate the **RIGHT** switch. The display will flash the top two LED rows and then begin scrolling the text "SET 3/8".
5. Fill the tank to the three-eighths point and then activate the **RIGHT** switch. The display will flash the top two LED rows and then begin scrolling the text "SET 1/2".
6. Fill the tank to the one-half point and then activate the **RIGHT** switch. The display will flash the top two LED rows and then begin scrolling the text "SET 5/8".
7. Fill the tank to the five-eighths point and then activate the **RIGHT** switch. The display will flash the top two LED rows and then begin scrolling the text "SET 3/4".
8. Fill the tank to the three-quarter point and then activate the **RIGHT** switch. The display will flash the top two LED rows and then begin scrolling the text "SET 7/8".
9. Fill the tank to the seven-eighths point and then activate the **RIGHT** switch. The display will flash the top two LED rows and then begin scrolling the text "SET FULL".
10. Fill the tank to the full point and then activate the **RIGHT** switch. The display will respond by flashing the top two LED rows and then start normal operation with the new calibration by displaying FULL (all LEDs on).

3.3.6. Calibration retention

Calibration data is saved in non-volatile memory (EEPROM) and the display does not need power to retain calibration data.

3.3.7. Invalid calibration

Calibration automatically makes the ITL40 a MASTER display if the calibration is valid. An invalid calibration is determined when any calibrated point is not at a higher level than the previous calibrated point, or if the sensor voltage falls outside of the valid minimum (0.4V) or maximum (4.8V) range.

An invalid calibration is acknowledged by flashing "X" four times and then scrolling the text "CHECK SENSOR VOLTS" followed by a continuous scroll of the voltage detected on the sensor's signal (pin 6).

 607 NW 27th Ave Ocala, FL 34475 Ph: 352-629-5020 or 1-800-533-3569 Fax: 352-629-2902 or 1-800-520-3473	SUITABLE FOR EXTERNAL DISTRIBUTION			PAGE	10 of 25	
	OPERATION MANUAL				DATE	9/24/2008
	PRODUCT GROUP	ITL40	P/N	118404-XX	REV	1.00
	PRODUCT	Intelli-Tank Level 40			BY	AMS

3.3.8. Calibration incomplete

If the calibration is not completed the display will continually flash the “incomplete calibration” error (section 3.1.3), during all subsequent power cycles. This indicates that a calibration was attempted but never completed.

Recalibrate the display completely to remove this error condition.

3.4. Self test

The ITL40 can check its hardware for proper operation by entering the password **RLLR LLRR**.

The display will turn all the LEDs ON and then cycle each LED OFF individually starting with the top LED. All LEDs will come on and begin flashing between full bright and the calibrated dim level for 5 seconds. The display will then scroll text indicating the self test condition.

Memory test

“MEM-PASS” Memory (EEPROM) is good.
 “MEM-FAIL” Memory (EEPROM) failure detected.

Sensor signal test (MASTER unit only)

“SIG-PASS” Sensor signal voltage within tolerance (0.4 volts to 4.8 volts).
 “SIG-FAIL” Sensor signal voltage out of tolerance (0.4 volts to 4.8 volts).

Communication wire test

“WIRE-PASS” Data communication lines good.
 “WIRE-FAIL” Data communication lines shorted or open.

If the self test password is used on a MASTER display all REMOTE displays will also perform their self test.

3.5. Setting the dim LED level

The display can be dimmed by applying system power to pin 4 (Dim Display input). The ITL40 has 9 levels of brightness available (9 = brightest, 1 = dimmest, default value is 3).

To select the dim level of the display use the magnetic switches to enter the password **RLLR LLLR**.

All of the LEDs will be illuminated during the set-up. Touch a magnet against the **RIGHT** switch and the display will dim to the next level and show the dim value number (9 through 1). Release the magnet and again touch it against the **RIGHT** switch again to drop to the next dim level. Once the dim level is at the dimmest setting (1) the next touch of the magnet will cycle to the highest dim level (9).

When the dim level is at the desired point activate the **LEFT** switch to save and exit.

3.6. Show software version, device settings, and errors

The ITL40 can display its setting by entering the password **RRRR RRRR**.

The display will scroll the software version, unit type, communication method, and then display any errors.

Software version

“Vx.x” Where x.x equals the numeric software version. For example, V1.0.

Unit type

“MASTER” The unit is set as a MASTER.
 “REMOTE” The unit is set as a remote.
 “CAL INCOMPLETE” A calibration was started but never completed.
 “UNKNOWN” The unit type cannot be determined – ERROR.

 607 NW 27th Ave Ocala, FL 34475 Ph: 352-629-5020 or 1-800-533-3569 Fax: 352-629-2902 or 1-800-520-3473	SUITABLE FOR EXTERNAL DISTRIBUTION			PAGE	11 of 25	
	OPERATION MANUAL				DATE	9/24/2008
	PRODUCT GROUP	ITL40	P/N	118404-XX	REV	1.00
	PRODUCT	Intelli-Tank Level 40			BY	AMS

Communication method

“1-WIRE” Using 1-wire communication method.
 “CAN” Using CAN communication method.

CAN device address (if communication method = CAN)

“ADDR=1” The unit ‘s CAN address is 1 (0xCB).
 “ADDR=2” The unit ‘s CAN address is 2 (0xCC).
 “ADDR=3” The unit ‘s CAN address is 3 (0xCD).
 “ADDR=4” The unit ‘s CAN address is 4 (0xCE).
 “ADDR=PCM” The unit ‘s CAN address is Pump Control Module (0xCA).

Error indications

“NO ERRORS” No errors detected.
 “MEM-ERROR” Memory error detected.
 “CAL-ERROR” Validation of calibration problem detected.
 “NO-COMM” Not receiving communication from MASTER display.
 “SIG-HIGH” Sensor signal voltage too high (greater than 4.8V).
 “SIG-LOW” Sensor signal voltage too low (less than 0.4V).
 “CAL NOT FINISHED” Calibration was started but not completed.
 “TYPE-BAD” Unit type cannot be determined (not MASTER, REMOTE, or CAL INCOMPLETE).

3.7. Configure the communication method

A MASTER display can communicate to other displays that are configured as remotes via CAN or 1-wire.

The 1-wire communication method is the default method and will work with ITL40 and ITL displays.

The CAN communication method is new for the ITL40 displays and is a more robust communication method. This method requires two wires (CAN high, CAN low) and approved J1939 CAN wiring and connectors. There should be two (2) 120 ohm terminating resistors located at the ends of the CAN bus (see section 6.3.5).

3.7.1. Configuring a display as a Master with 1-wire communications

Enter the password **LRL LLLR** to set the communication method to 1-wire. If the display was not previously a MASTER display, calibrate the display (see section 3.3).

3.7.2. Configuring a display as a Remote with 1-wire communications

Enter the password **LRL LLLR** to set the communication method to 1-wire. If the display is a MASTER display, enter the password **LRLR LRLR** to turn the display into a REMOTE.

3.7.3. Configuring a display as a Master with CAN communications

Enter the password **LRL LLRL** to set the communication method to CAN. If the display was not previously a MASTER display, calibrate the display (see section 3.3).

Choose the CAN identification address to use (either address 1, 2, 3, 4, or PCM) and enter the appropriate password to set the address (**LRRR LLLL** address 1, **LRRR LLLR** address 2, **LRRR LRRR** address 3, **LRRR RLLR** address 4, **LRRR LRLR** address PCM). All REMOTE displays that are to mimic this Master display must have their addresses matching the MASTER’s.

3.7.4. Configuring a display as a Remote with CAN communications

Choose the CAN identification address to use (either address 1, 2, 3, 4, or PCM) and enter the appropriate password to set the address (**LRRR LLRL** address 1, **LRRR LLRR** address 2, **LRRR LRRL** address 3,

 607 NW 27th Ave Ocala, FL 34475 Ph: 352-629-5020 or 1-800-533-3569 Fax: 352-629-2902 or 1-800-520-3473	SUITABLE FOR EXTERNAL DISTRIBUTION			PAGE	12 of 25	
	OPERATION MANUAL				DATE	9/24/2008
	PRODUCT GROUP	ITL40	P/N	118404-XX	REV	1.00
	PRODUCT	Intelli-Tank Level 40			BY	AMS

LRRR RLLL address 4). All REMOTE displays that are to mimic the MASTER display must have their addresses matching the MASTER's.

The display can also be configured to mimic a Class 1 Pump Sensor Module (p/n 111097) by entering the password for the desired tank (**LRRR LRL** PCM tank 1, **LRRR RLRL** PCM tank 2, **LRRR RLRR** PCM tank 3).

3.8. Configure a custom message scroll

The ITL40 scrolls a custom message during start-up. The default scroll text is "Class 1" but the text can be custom configured to a desired message (maximum of 21 characters allowed).

List of available characters.

A	B	C	D	E	F	G	H	I	J	K	L	M	N	O	P	Q	R	S	T	U	V
W	X	Y	Z	SP	0	1	2	3	4	5	6	7	8	9	+	-	/	=	?	.	

Enter the password **LLLL LRLR** and the display will show the first available character - "A".

Use the LEFT and RIGHT magnetic switches to enter the desired text.

- The LEFT magnetic switch changes the character. Each LEFT switch activation moves forward or backward through the available characters. Wait two seconds between switch activations and the direction reverses.
- The RIGHT magnetic switch saves the displayed character to memory.

There are three methods of exiting...

- Save two SPACE characters in a row.
- Configure the maximum number of characters (21).
- Turn OFF power to the ITL40.

The custom message scroll can also be configured through a CAN message. Contact Class 1 for details.

3.9. Use the display reference mark

The level the ITL40 shows may be difficult to distinguish at a distance for some viewers. The ITL40 can be configured with a reference mark at the top of the display (single LED ON) which will help quickly determine level.

- Enter the password **LLRR RRRR** to turn the reference mark ON.
- Enter the password **LLRR LLLL** to turn the reference mark OFF.
The default for the reference mark is OFF.



 607 NW 27th Ave Ocala, FL 34475 Ph: 352-629-5020 or 1-800-533-3569 Fax: 352-629-2902 or 1-800-520-3473	SUITABLE FOR EXTERNAL DISTRIBUTION		PAGE	13 of 25	
	OPERATION MANUAL			DATE	9/24/2008
PRODUCT GROUP	ITL40	P/N	118404-XX	REV	1.00
PRODUCT	Intelli-Tank Level 40		BY	AMS	

3.10. Slosh dampening feature

Some applications (off-road vehicles, etc) may submit the tank to conditions of extreme movement which causes the fluid to slosh producing significant fluctuation in the displayed tank level.

The ITL40 can counteract these conditions by averaging the rhythmic changes (sloshing) detected by the pressure sensor creating a more consistent displayed tank level.

Example with the slosh dampening feature DISABLED (default).

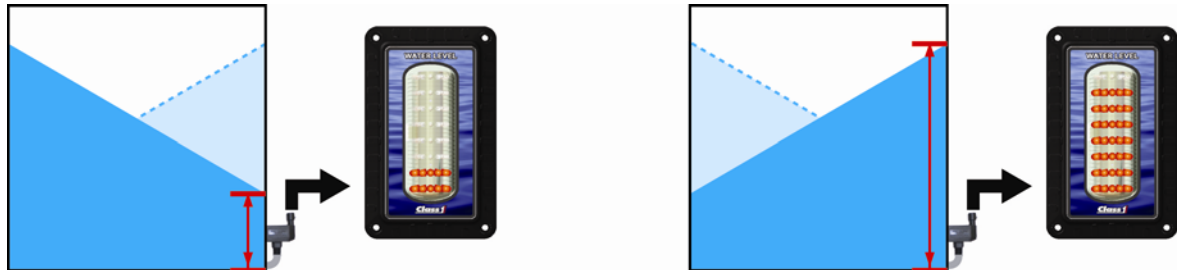

Example with the slosh dampening feature ENABLED.

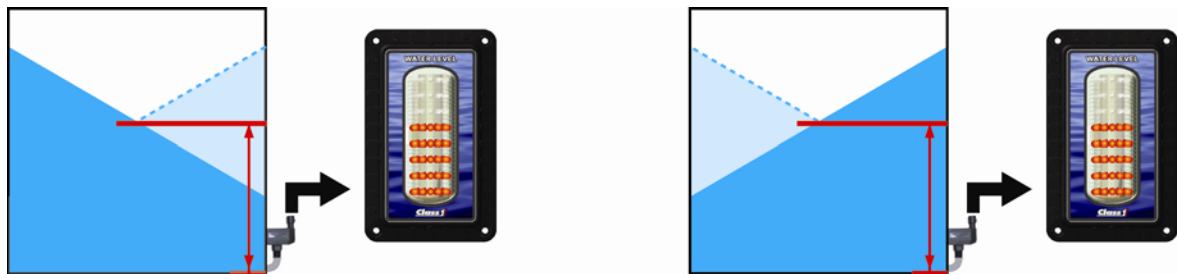

- Enable the slosh dampening feature by entering the password **LRRL LRRL**.
The display will scroll "SLOSH ON" to indicate that the feature has been enabled.
- Disable the slosh dampening feature by entering the password **LRRL LRRR**.
The display will scroll "SLOSH OFF" to indicate that the feature has been disabled.

 607 NW 27th Ave Ocala, FL 34475 Ph: 352-629-5020 or 1-800-533-3569 Fax: 352-629-2902 or 1-800-520-3473	SUITABLE FOR EXTERNAL DISTRIBUTION			PAGE	14 of 25	
	OPERATION MANUAL				DATE	9/24/2008
	PRODUCT GROUP	ITL40	P/N	118404-XX	REV	1.00
	PRODUCT	Intelli-Tank Level 40			BY	AMS

4. Password list

RLLR LRRL	1 point calibration (section 3.3.1)
RLLR LLRL	2 point calibration, empty then full (section 3.3.2)
RLLR LRRR	2 point calibration, full then empty (section 3.3.4)
RLLR LRLR	5 point calibration (section 3.3.4)
RLLR RLLR	9 point calibration (section 3.3.5)
RLLR LLRR	Self test (section 3.4)
LRLR LRLR	Configure display as Remote display (section 2.3)
RLLR LLLR	Configure dim level (section 3.5)
LLRR LLRR	Display voltage (section 7.2)
LRLR LLLR	Configure for 1-wire communications (section 3.7)
LRLR LLRL	Configure for CAN communications (section 3.7)
LRRR LLLL	Configure as Master display with CAN address 1 (section 3.7.3)
LRRR LLLR	Configure as Master display with CAN address 2 (section 3.7.3)
LRRR LRRR	Configure as Master display with CAN address 3 (section 3.7.3)
LRRR RLLR	Configure as Master display with CAN address 4 (section 3.7.3)
LRRR LRLR	Configure as Master display with CAN address PCM (section 3.7.3)
LRRR LLRL	Configure as Remote display with CAN address 1 (section 3.7.4)
LRRR LLRR	Configure as Remote display with CAN address 2 (section 3.7.4)
LRRR LRRL	Configure as Remote display with CAN address 3 (section 3.7.4)
LRRR RLLL	Configure as Remote display with CAN address 4 (section 3.7.4)
LRRR LRLL	Configure as Remote display for use with Pump Sensor Module, Tank 1 (section 3.7.4)
LRRR RLRL	Configure as Remote display for use with Pump Sensor Module, Tank 2 (section 3.7.4)
LRRR RLRR	Configure as Remote display for use with Pump Sensor Module, Tank 3 (section 3.7.4)
LRRL LRRL	Slosh dampening feature enabled (section 3.10)
LRRL LRRR	Slosh dampening feature disabled (section 3.10)
LLRR LLLL	Reference mark turned OFF (section 3.9)
LLRR RRRR	Reference mark turned ON (section 3.9)
LLRR LRRL	Load defaults (remote, 1-wire, dim level 3, "CLASS 1" scroll, slosh dampening OFF)
LLLL LRLR	Configure custom start-up text scroll (section 3.8)

 607 NW 27th Ave Ocala, FL 34475 Ph: 352-629-5020 or 1-800-533-3569 Fax: 352-629-2902 or 1-800-520-3473	SUITABLE FOR EXTERNAL DISTRIBUTION OPERATION MANUAL		PAGE 15 of 25
	PRODUCT GROUP ITL40	P/N 118404-XX	DATE 9/24/2008
PRODUCT Intelli-Tank Level 40			REV 1.00
			BY AMS

5. Installation

5.1. Cutout dimensions

The display requires a cutout as shown. The display is water tight and may be mounted in any location on the operator's panel.

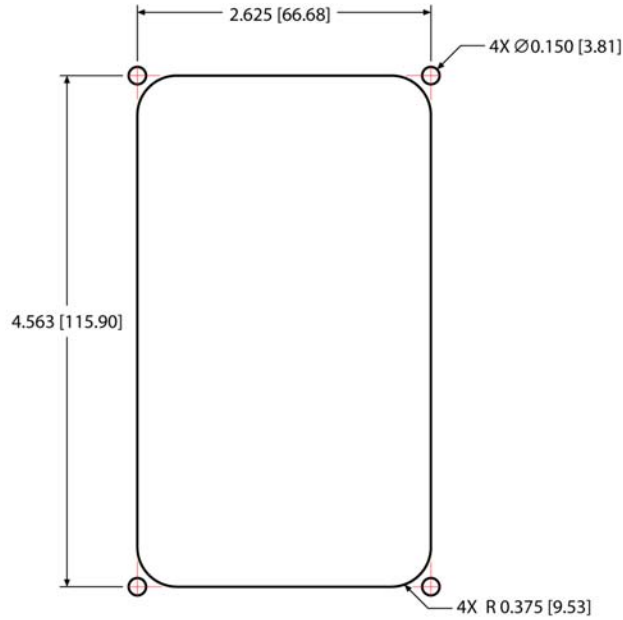

Unit of scale: inches [millimeters]

5.2. Outer bezel dimensions



Unit of scale: inches [millimeters]

 607 NW 27th Ave Ocala, FL 34475 Ph: 352-629-5020 or 1-800-533-3569 Fax: 352-629-2902 or 1-800-520-3473	SUITABLE FOR EXTERNAL DISTRIBUTION			PAGE	16 of 25
	OPERATION MANUAL			DATE	9/24/2008
PRODUCT GROUP	ITL40	P/N	118404-XX	REV	1.00
PRODUCT	Intelli-Tank Level 40			BY	AMS

5.3. Label orientation

Before mounting the display and adhering the label insure that the display is situated correctly (TOP is UP). Refer to the drawing for orientation.

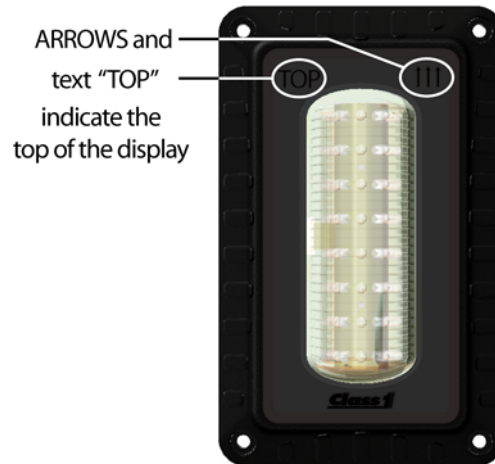

p/n 117691

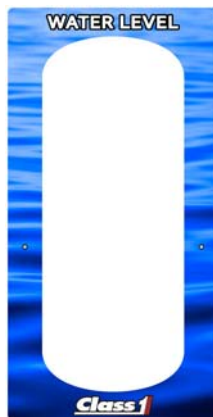

p/n 117692



p/n 117693

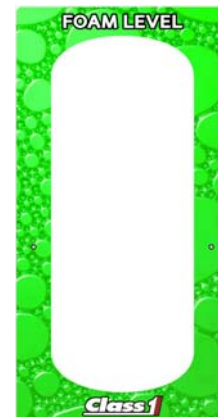

5.4. Pressure sensor

The pressure sensor (p/n 102162) is threaded for 1/4" NPT and must be mounted vertically as depicted to insure an accurate reading.

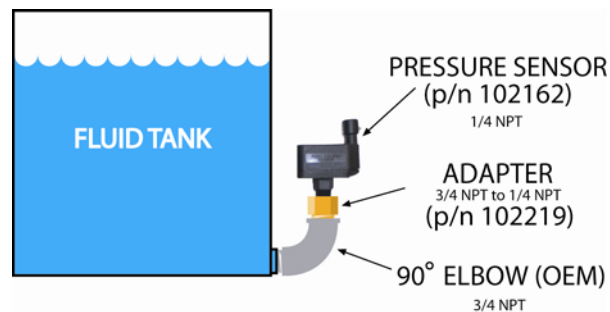

5.4.1. Approved fluids

The pressure sensor has been tested and approved for water and Class A and B foams.

 607 NW 27th Ave Ocala, FL 34475 Ph: 352-629-5020 or 1-800-533-3569 Fax: 352-629-2902 or 1-800-520-3473	SUITABLE FOR EXTERNAL DISTRIBUTION			PAGE	17 of 25	
	OPERATION MANUAL				DATE	9/24/2008
	PRODUCT GROUP	ITL40	P/N	118404-XX	REV	1.00
	PRODUCT	Intelli-Tank Level 40			BY	AMS

6. Wiring

6.1. ITL40 connector

The ITL40 has one connector and the following definitions apply:

Mating connector: Deutsch DT06-12SB BLACK		
Mating sockets: Deutsch 0462-201-16141		
Wedge lock: W12S Recommended wire gage: 16-18 AWG		
PIN	CIRCUIT	DESCRIPTION
1	SUPPLY (+)	(INPUT) – battery voltage (+9VDC...+32VDC)
2	CAN HIGH	(DATA) – SAE J1939 CAN 2.0B, 250Kbits/s
3	CAN SHIELD	(DATA) – SAE J1939 CAN 2.0B, 250Kbits /s
4	DIM DISPLAY	(INPUT) – Dim display input (positive polarity)
5	Sensor REF	(OUTPUT) – pressure sensor supply (+5VDC)
6	Sensor SIGNAL	(INPUT) – pressure sensor signal (+0.5VDC to +4.5VDC)
7	Sensor GND	(OUTPUT) – pressure sensor ground
8	----	----
9	1-WIRE SIG	(DATA) – Class 1proprietary communication
10	GROUND	(OUTPUT) – common ground
11	CAN LOW	(DATA) – SAE J1939 CAN 2.0B, 250Kbits /s
12	SUPPLY (-)	(INPUT) – battery ground



6.2. Pressure sensor connector

The pressure sensor has one connector and the following definitions apply:

Mating connector: Packard Metri-Pack 150 series, 12047909		
Mating sockets: Packard Metri-Pack 150 series, 12103881		
Recommended wire gage: 18-20 AWG		
PIN	CIRCUIT	DESCRIPTION
A	SUPPLY (+)	(INPUT) – pressure sensor supply (+5VDC)
B	SUPPLY (-)	(INPUT) – pressure sensor ground
C	Signal	(OUTPUT) – pressure sensor signal (+0.5VDC to +4.5VDC)



 607 NW 27th Ave Ocala, FL 34475 Ph: 352-629-5020 or 1-800-533-3569 Fax: 352-629-2902 or 1-800-520-3473	SUITABLE FOR EXTERNAL DISTRIBUTION			PAGE	18 of 25	
	OPERATION MANUAL			DATE	9/24/2008	
	PRODUCT GROUP	ITL40	P/N	118404-XX	REV	1.00
	PRODUCT	Intelli-Tank Level 40			BY	AMS

6.3. Communication wiring examples

The ITL40 display can be set up to use the 1-wire or CAN communication methods. The simplest system would be comprised of a single ITL40 MASTER display.

6.3.1. 1-wire method, 1 MASTER and 2 REMOTES

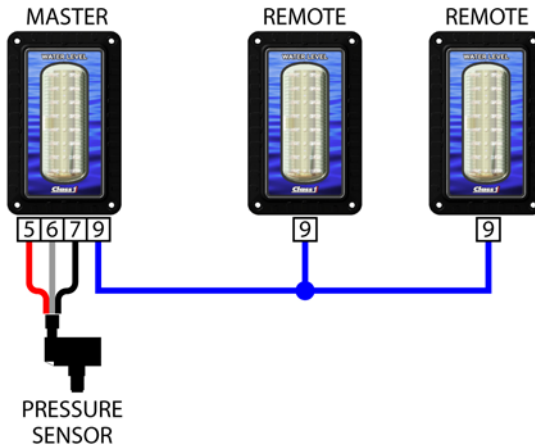

System configured with 1-wire communication method. Make certain that the ground for each display is tied to a common point or the REMOTE displays will not receive communication data from the MASTER display.

6.3.2. 1-wire method, 2 MASTERS and 2 REMOTES

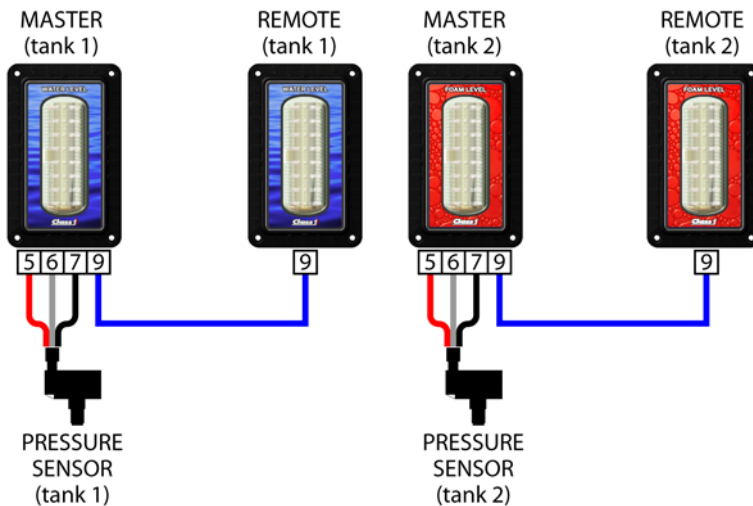

System configured with 1-wire communication method. Make certain that the two MASTER 1-wire data lines are not connected and that the ground for each display is tied to a common point or the REMOTE displays will not receive communication data from their associated MASTER display.

 607 NW 27th Ave Ocala, FL 34475 Ph: 352-629-5020 or 1-800-533-3569 Fax: 352-629-2902 or 1-800-520-3473	SUITABLE FOR EXTERNAL DISTRIBUTION <h2 style="text-align: center;">OPERATION MANUAL</h2>			PAGE 19 of 25
	PRODUCT GROUP ITL40	P/N 118404-XX	DATE 9/24/2008	REV 1.00
PRODUCT Intelli-Tank Level 40			BY AMS	

6.3.3. CAN method, 1 MASTER and 2 REMOTES

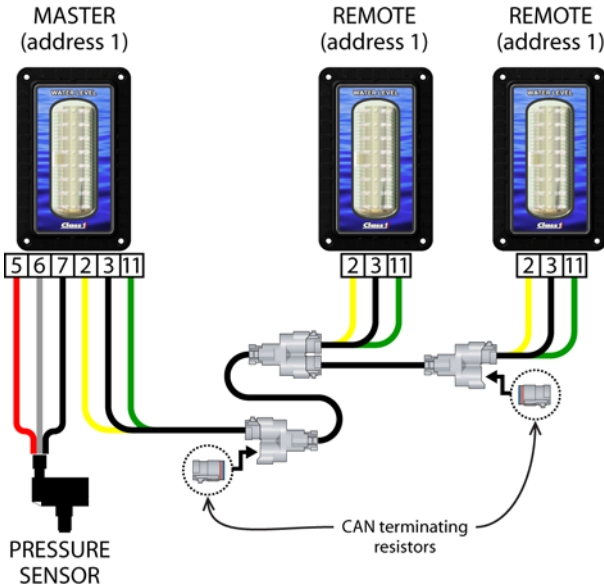

System configured with CAN communication method. This example shows one MASTER display (configured with address 1) communicating with 2 REMOTE displays (configured with address 1).

Two CAN terminating resistors (p/n DT06-3S-P006) are required in the system (one at each end of the CAN bus).

6.3.4. CAN method, 2 MASTERS and 2 REMOTES

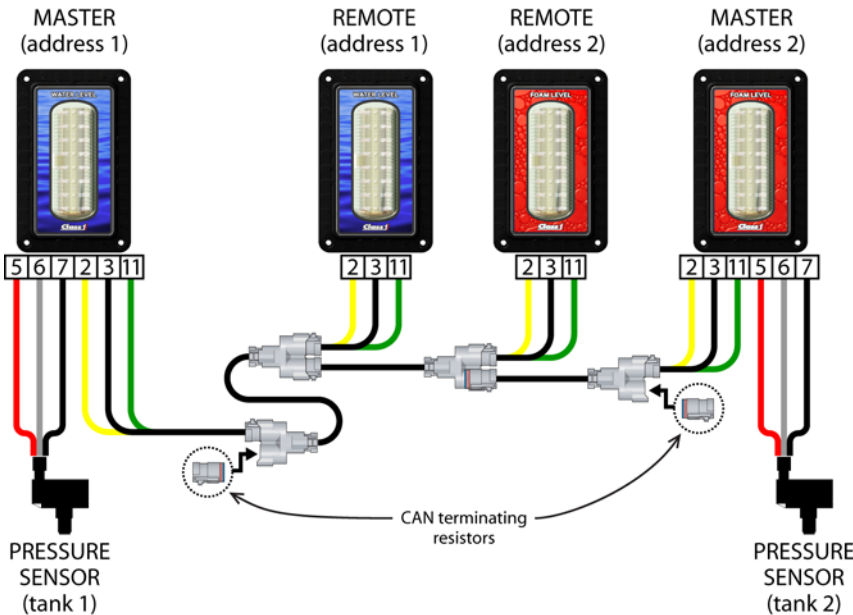

System configured with CAN communication method. This example shows two MASTER displays (configured with address 1 and address 2) communicating with 2 REMOTE displays (configured with address 1 and address 2). REMOTE display address 1 only follows the indications of MASTER display address 1, and REMOTE display address 2 only follows the indications of MASTER display address 2.

Two CAN terminating resistors (p/n DT06-3S-P006) are required in the system (one at each end of the CAN bus).

 607 NW 27th Ave Ocala, FL 34475 Ph: 352-629-5020 or 1-800-533-3569 Fax: 352-629-2902 or 1-800-520-3473	SUITABLE FOR EXTERNAL DISTRIBUTION OPERATION MANUAL			PAGE	20 of 25
	PRODUCT GROUP	ITL40	P/N	118404-XX	DATE
PRODUCT	Intelli-Tank Level 40			REV	1.00
				BY	AMS

6.3.5. Terminating resistor requirement (CAN communication)

Two terminating resistors (120 Ohm) are required on the CAN bus for proper operation (one at each end of the CAN bus). Only two terminating resistors are allowed on a CAN bus.

Terminating resistor p/n DT06-3S-P006

CAN 3-way "Y" connector p/n DT04-3P-P007

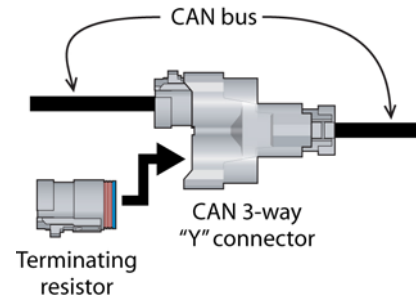

6.4. Communication compatibility with Class 1 products

The ITL40 display is compatible with other Class 1 CAN and 1-wire products.

6.4.1. 1-wire compatibility

An ITL40 display configured with 1-wire communication is compatible with...

- 4 light remote driver module (p/n 106877)
- Pump input sensor module (p/n 111097)
- Mini remote driver module (p/n 112648)
- Mini remote dash gauge (p/n 112649)
- 4 and 5 light ITL displays (p/n 106299, 106296, 108858, 108859, 113739, 114378, 114005, 114379)

6.4.2. CAN compatibility





An ITL40 display configured with CAN communications is compatible with...

- Command Master (p/n 111084, 111085, 111086)
- Pump input sensor module (p/n 111097)
- 4 and 5 light ITL displays (p/n 113739, 114378, 114005, 114379)

 607 NW 27th Ave Ocala, FL 34475 Ph: 352-629-5020 or 1-800-533-3569 Fax: 352-629-2902 or 1-800-520-3473	SUITABLE FOR EXTERNAL DISTRIBUTION OPERATION MANUAL			PAGE	21 of 25
	PRODUCT GROUP		ITL40	P/N	118404-XX
	PRODUCT		Intelli-Tank Level 40		
				DATE	9/24/2008
			REV	1.00	
			BY	AMS	

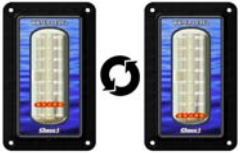
7. Troubleshooting

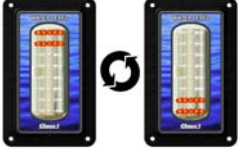
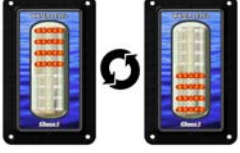
7.1. Evaluation table

Condition	Visual	Evaluate
Bottom two LEDs rows alternate flashing. Signal voltage too low (less than 0.4 V).		Check sensor wiring. Ensure +5V at pin A, ground at pin B and at least 0.4V at pin C (Signal). Use password LLRR LLRR to view sensor voltage on display.
Top two LED rows alternate flashing. Signal voltage too high (greater than 4.8V).		Check sensor wiring. Ensure +5V at pin A, ground at pin B and no more than 4.8V at pin C (Signal). Use password LLRR LLRR to view sensor voltage on display.
Middle two LED rows alternate flashing. Memory error.		Perform self test RLLR LLRR. If it shows "MEM-FAIL" replace display, otherwise recalibrate or reset as REMOTE.
Outer two LED rows alternate flashing. Invalid calibration.		Try to recalibrate. If condition remains, check if the sensor signal voltage (pin C) changes as tank level increases. If it doesn't, replace sensor. If it does, verify depth of tank. It may be impossible to calibrate a tank with a depth of less than 6 inches.
Bottom four and Upper four LEDs rows alternate flashing. Not receiving data.		The display is configured as a REMOTE. Recalibrate if a MASTER is required. If the display is supposed to be a REMOTE check communication data lines for continuity.
No LEDs on.		Check power (Pin 1) and ground (Pin 12) connection.
Master Tank level unit does not change when actual tank level is changing.	No picture	Check sensor wiring. Ensure sensor signal voltage (Pin C) is varying. If it does, check for same signal changes at Pin 6 of tank level connector (if it is not the same - repair wiring). If signal is good at both locations try re-calibrating.
Remote Tank level unit does not follow Master display.	No picture	Perform self test. If self test is good, verify communication data lines for continuity. Insure 1-wire data line is not routed near noisy power or RF sources.

 607 NW 27th Ave Ocala, FL 34475 Ph: 352-629-5020 or 1-800-533-3569 Fax: 352-629-2902 or 1-800-520-3473	SUITABLE FOR EXTERNAL DISTRIBUTION			PAGE	22 of 25	
	OPERATION MANUAL			DATE	9/24/2008	
	PRODUCT GROUP	ITL40	P/N	118404-XX	REV	1.00
	PRODUCT	Intelli-Tank Level 40		BY	AMS	

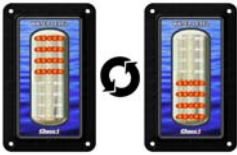
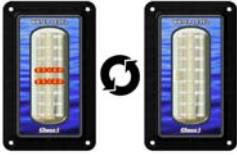
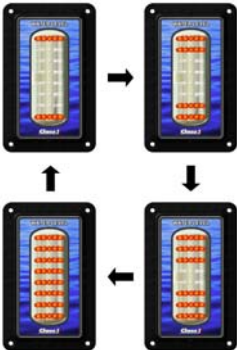
Condition	Visual	Evaluate
No passwords are accepted.		<p>If the display flashes "X" four times after entering a password, insure the display is installed right side up. During power-up the display should turn on all LEDs and then cycle them OFF starting with the top row, then the display should scroll the custom greeting from right to left.</p> <p>Check that the left and right magnetic switches are recognized by activating each switch and verifying that the associated LEDs illuminate.</p>
The bottom four LED rows are on and occasionally they go out and the top four LED rows flash and then return to the bottom four LED rows on (or vice-versa). (REMOTE).		<p>Check for large noise spikes on the 1-wire data line.</p> <p>Insure that the display's ground potential is the same as the MASTER's.</p> <p>Insure that the data line is not chaffed and making contact with other electrical wires.</p>
The points calibrated seemed to have changed.	No picture	<p>Check the pressure sensor for problems.</p> <p>Recalibrate the display and take a voltage reading from the sensor (pin 6 on the display's connector) at each calibration point. When the calibration points again look wrong check the voltages at those points and determine if they are the same as the voltage reading taken during calibration – if they are not then replace the sensor.</p>
Unit will not dim display.	No picture	<p>Insure the Dim input voltage on Pin 4 is at least 9V. Recalibrate dim setting (RLLR LLLR). If display does not dim LEDs while in the dim configure mode, replace display.</p>
The middle two LED rows are flashing together.		<p>A calibration was started on the display but not completed correctly. Set the display to a REMOTE display (LRLR LRLR) or calibrate it as a MASTER (follow calibration steps exactly).</p>
LEDs cycle ON toward the center continuously.		<p>The display has had a unit type memory error.</p> <p>Attempt to set the display back to REMOTE or MASTER as required.</p> <p>Replace the display if this error cannot be corrected.</p>

7.2. Using the display to verify pressure sensor signal voltage

The display can show the voltage level that it detects on the pressure sensor signal line by entering the password **LLRR LLRR**.

The display will then scroll the text "VOLTS" and then continue to scroll the voltage detected at pin 6.

The display will continue showing the voltage until either of the magnetic switches is activated.

 607 NW 27th Ave Ocala, FL 34475 Ph: 352-629-5020 or 1-800-533-3569 Fax: 352-629-2902 or 1-800-520-3473	SUITABLE FOR EXTERNAL DISTRIBUTION			PAGE	23 of 25	
	OPERATION MANUAL				DATE	9/24/2008
	PRODUCT GROUP	ITL40	P/N	118404-XX	REV	1.00
	PRODUCT	Intelli-Tank Level 40			BY	AMS

8. Glossary

1-wire	Proprietary communication method that uses only one wire for data transfer.
C1	<u>C</u> lass <u>1</u>
CAN	<u>C</u> ontroller <u>A</u> rea <u>N</u> etwork. SAE J1939 communication method.
EEPROM	<u>E</u> lectrically <u>E</u> rasable <u>P</u> rogrammable <u>R</u> ead- <u>O</u> nly <u>M</u> emory. The memory of the tank level display, used to store the display information (tank level points, display type, dim value, etc).
ESD	<u>E</u> lectro <u>S</u> tatic <u>D</u> ischarge.
Foam A	Class "A" type foam used when fighting fires where the cooling effect of water is of prime importance in extinguishing (wood, paper, etc.)
Foam B	Class "B" type foam used when fighting fires involving flammable liquids where blanketing or smothering effect of water is of prime importance in extinguishing (gasoline, etc.)
IP	<u>I</u> ngress <u>P</u> rotection (IP 67, etc).
ITL	<u>I</u> ntelli- <u>T</u> ank <u>L</u> evel. Class 1's 4 and 5 light tank level display.
ITL40	Intelli-Tank Level 40. The tank level display.
LED	<u>L</u> ight <u>E</u> mitting <u>D</u> iode. The lights on the display used to show tank level and information.
MASTER	Master display. The tank level display wired to the sensor. This display transmits data to other remote displays.
NPT	<u>N</u> ormal <u>P</u> ipe <u>T</u> aper. Pipe thread specification.
OEM	<u>O</u> riginal <u>E</u> quipment <u>M</u> anufacturer.
PCM	<u>P</u> ump <u>C</u> ontrol <u>M</u> odule. Class 1 module p/n 111097.
P/N	part <u>n</u> umber
PSI	<u>P</u> ounds per <u>S</u> quare <u>I</u> nch. Pressure measurement.
REMOTE	Remote display. A tank level display that receives data from the master unit. The remote display will only display what the master display commands.
SAE	<u>S</u> ociety of <u>A</u> utomotive <u>E</u> ngineers.
Sensor	The pressure sensor.
System voltage	The normal power level used by the system or vehicle. This voltage level will normally come from the vehicle's battery and charging system (vehicle ignition, vehicle power, etc.)
TBD	<u>T</u> o <u>B</u> e <u>D</u> eveloped.

 607 NW 27th Ave Ocala, FL 34475 Ph: 352-629-5020 or 1-800-533-3569 Fax: 352-629-2902 or 1-800-520-3473	SUITABLE FOR EXTERNAL DISTRIBUTION			PAGE	24 of 25	
	OPERATION MANUAL				DATE	9/24/2008
	PRODUCT GROUP	ITL40	P/N	118404-XX	REV	1.00
	PRODUCT	Intelli-Tank Level 40			BY	AMS

9. Technical details

9.1. Technical details

Product category	ITL40 (Intelli-Tank Level 40)
Voltage range	+9VDC...+32VDC
Power consumption	
@13.8VDC (25°C)	100 mA
@27.6VDC (25°C)	52 mA
Operational temperature range	-40°C...+85°C
Environmental range	IP 67
CAN specification	SAE J1939 proprietary, 250 Kbits/second
1-Wire specification	Class 1 proprietary, 425 bits/second
Protection	Internal thermal fuse Reverse voltage protection (pins 1 and 12 of connector) CAN buses protected to 24V ESD voltage protected to SAE J1113 specification for heavy duty trucks Transient voltage protected to SAE J1113 specification for heavy duty trucks
Dimensions (W x H x D) in inches [mm]	3.185 [80.90] x 5.125 [130.17] x 2.150 [54.61]
Weight in ounces [grams]	7.9 [223.96]

9.2. WEEE (Waste of Electrical and Electronic Equipment) directive



This symbol [crossed-out wheeled bin WEEE Annex IV] indicates separate collection of waste electrical and electronic equipment in the European Union countries. Please do not throw the equipment into the domestic refuse. Each individual European Union member state has implemented the WEEE regulations into national law in slightly different ways. Please follow your national law when you want to dispose of any electrical or electronic products.

More details can be obtained from your national WEEE recycling agency.

9.3. CE statement



This device complies with the European Regulations for Electromagnetic Compatibility (EMC) of the European Union and it is equipped with the CE mark. This unit must be used in accordance with the details specified within this manual.

 Unit of IDEX Corporation
 607 NW 27th Avenue
 Ocala, FL 34475 U.S.A
 Phone: 1.800.533.3569 • 352.629.5020
 Fax: 1.800.520.3473 • 352.629.2902
www.class1.com

 607 NW 27th Ave Ocala, FL 34475 Ph: 352-629-5020 or 1-800-533-3569 Fax: 352-629-2902 or 1-800-520-3473	SUITABLE FOR EXTERNAL DISTRIBUTION			PAGE	25 of 25	
	OPERATION MANUAL				DATE	9/24/2008
	PRODUCT GROUP	ITL40	P/N	118404-XX	REV	1.00
	PRODUCT	Intelli-Tank Level 40			BY	AMS

10. 板料信息声明 (RoHS 声明) – Declaration Information Sheet (RoHS Declaration)

10.1. 产品中有毒和有害的物质或成份的名称和含量 – (NAMES AND CONTENTS OF THE TOXIC AND HAZARDOUS SUBSTANCES OR ELEMENTS IN THE PRODUCTS)

Class 1 is committed to comply with the [Management Methods on Control of Pollution from Electronic Information Products of China \(China RoHS\)](#). The RoHS Directive restricts substances including lead (Pb), mercury (Hg), Cadmium (Cd), hexavalent chromium (CrVI) and certain halogenated flame retardants such as polybrominated biphenyls (PBB) and polybrominated diphenyl ethers (PBDE) in electrical and electronic equipment.

零件名称 Parts	有毒和有害的物质或成份 TOXIC AND HAZARDOUS SUBSTANCES OR ELEMENTS					
	铅 (Pb)	汞 (Hg)	六价铬 (CrVI)	多溴联苯 (PBBs)	多溴二苯醚 (PBDEs)	镉 (Cd)
基准 Base	○	○	○	○	○	○
盒子 Box	○	○	○	○	○	○
镀层 Coating	○	○	○	○	○	○
面板 Faceplate	○	○	○	○	○	○
标签 Label	○	○	○	○	○	○
透镜 Lens	○	○	○	○	○	○
印制电路 PCB	X	○	○	○	○	○
元器件 Components	X	○	○	○	○	○
连接器 Connector	○	○	○	○	○	○
密封垫 Gasket	○	○	○	○	○	○
螺钉 Screw	○	○	○	○	○	○

○ : 表示该有毒有害物质在该部件所有均质材料中的含量均在SJ/T 11363-2006标准规定的限量要求以下。

○ : Indicates that this hazardous substance contained in all homogeneous materials of this part is below the limit requirement in SJ/T 11363-2006.

× : 表示该有毒有害物质至少在该部件的某一均质材料中的含量超出SJ/T 11363-2006标准规定的限量要求。

× : Indicates that this hazardous substance contained in at least one of the homogeneous materials of this part is above the limit requirement in SJ/T 11363-2006.



除非另外特别的标注,此标志为针对所涉及产品的环保使用期限标志.此环保使用期限只适用于产品在产品手册中所规定的条件下工作.

The Environment-Friendly Use Period (EFUP) for all enclosed products and their parts are per the symbol shown here, unless otherwise marked. The Environment-Friendly Use Period is valid only when the product is operated under the conditions defined in the product manual.