

# Contents

## Intelli-Tank

### Water/foam tank level display with '*Drip*' Empty

Contents	.....	1
Revision log	.....	2
Overview	.....	3
Operation	.....	4
Installation	.....	6
Wiring	.....	8
Calibration	.....	10
Dim function	.....	13
Self test	.....	13
Passwords	.....	14
Troubleshooting	.....	15

# Revision log

Rev	Date	Changes
021502	15 Feb 2002	Initial release.
050304	3 May 2004	Added expanded step-by-step instructions for 5 and 9 point calibrations.
092204	22 Sept 2004	Added “drip” empty indication description.
062805	28 June 2005	Added revision log and “new information” symbol. Added “incomplete calibration” indication. Added 1-point calibration method. Changed calibration procedure to show step-by-step procedure for each calibration method. Changed “set unit as remote” password to <b>LRLR LRLR</b> . Added note detailing how to cancel a calibration in progress.
071006	10 July 2006	Added magnetic switch activation detail.



The changes to this manual for revision 071006 will have the “new information” symbol to the left of the highlighted changed or added section.

The revision number of this manual is located on the bottom of each page to the left of the page number.

# Overview

The Intelli-Tank 4 light tank level is designed to display a liquid's volume to an eighth of a tank level accuracy through 180-degree viewable ultra-bright LEDs. The unit set as a Master uses a 0 – 5 PSI pressure transducer to obtain tank level information and then relays that information along the data line to units set as Remotes. Multiple Remote units can be linked to the Master tank level unit.

Tank Level Gauge	C1 – PN	106299 – <b>12V</b> 106296 – <b>24V</b>
Pressure Transducer	C1 – PN	102162
Installation Harness	C1 – PN	106690 – Master 106691 – Remote
User Manual	C1 – PN	106759

## Modes of Operation:

**Master** When the unit is calibrated with a proper pressure signal it automatically becomes a Master Unit and will send tank level information along the 1-wire data transfer line to all other Remote units on the line.

**Remote** Units are initially shipped as Remote units. A Remote unit only requires power, ground and the 1-wire data transfer line. The Remote unit mimics the Master unit's display by reading the appropriate information on the 1-wire data transfer line.

**Self Test** When the self test password is entered the unit will perform a self test and display the results on the display. A Master unit will command all Remote units to perform the self test also.

*Note: All units are shipped as Remote units. A valid calibration will set the unit as a Master. A Master can be reset as a Remote by entering a password.*

# Operation

When the unit is first powered up the LEDs will cycle on individually starting with the bottom LED (LED 1) and then the LEDs will show current status.

- A **Master** unit properly connected to a functioning transducer will display current tank level information.
- A **Master** unit not connected to a pressure transducer will alternately flash the bottom two LEDs.
- A **Remote** unit connected to a Master unit (through the 1-wire data line) will mimic the Master unit's LED condition and flash rate.
- A **Remote** unit not connected to a Master unit will alternately flash the upper two LEDs and the lower two LEDs. This indicates a "no data" condition.

## Level indications:

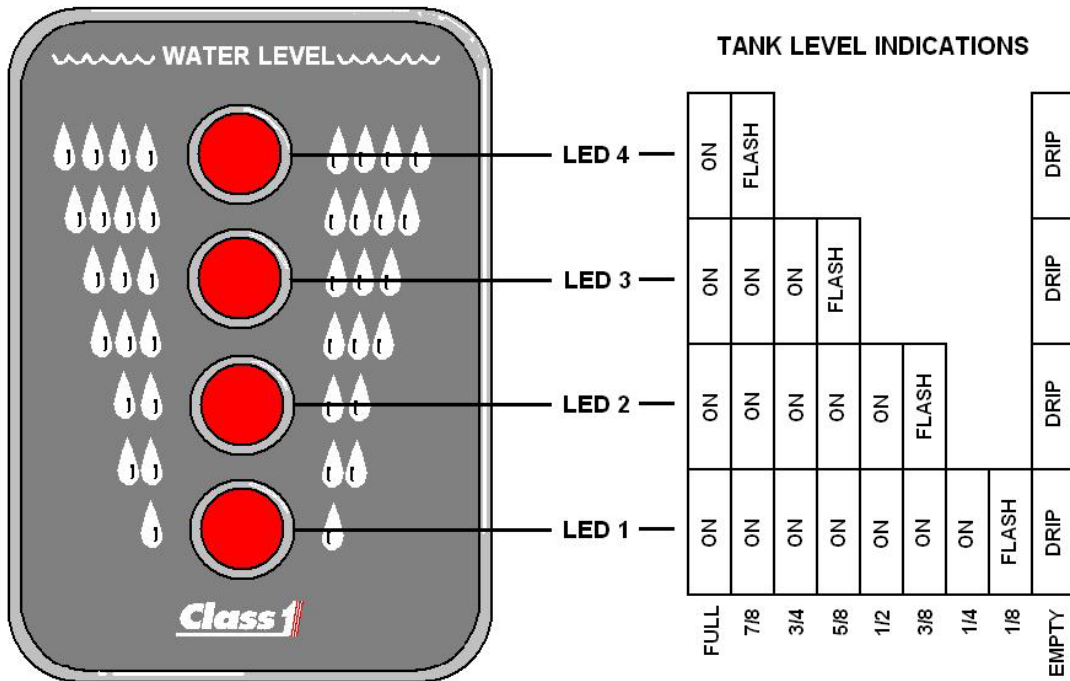

DRIP = cascades LEDs from top (LED 4) to bottom (LED 1), pauses, and repeats.

**Miscellaneous indications:**

<b>Condition</b>	<b>LED 4</b>	<b>LED 3</b>	<b>LED 2</b>	<b>LED 1</b>
Invalid calibration	AlternaFLASH			AlternaFLASH
Incomplete calibration		Fast FLASH	Fast FLASH	
EEPROM error		AlternaFLASH	AlternaFLASH	
Signal voltage above 4.8V	AlternaFLASH	AlternaFLASH		
Signal voltage below .4V			AlternaFLASH	AlternaFLASH
Remote "NO DATA"	AlternaFLASH		AlternaFLASH	
User Error (wave off) 4 quick cycles		ON	ON	
	ON			ON

The tank level has two flash rates: FAST (1.6Hz) and SLOW (.8Hz). AlternaFLASH flashes two lights alternately at the SLOW flash rate.

"Wave off" pattern : two center LEDs, two outer LEDs flashing quickly for 8 cycles.

# Installation

**Intelli-Tank display** The display requires a cutout as shown. The unit is water tight and may be mounted in any location on the operator's panel.

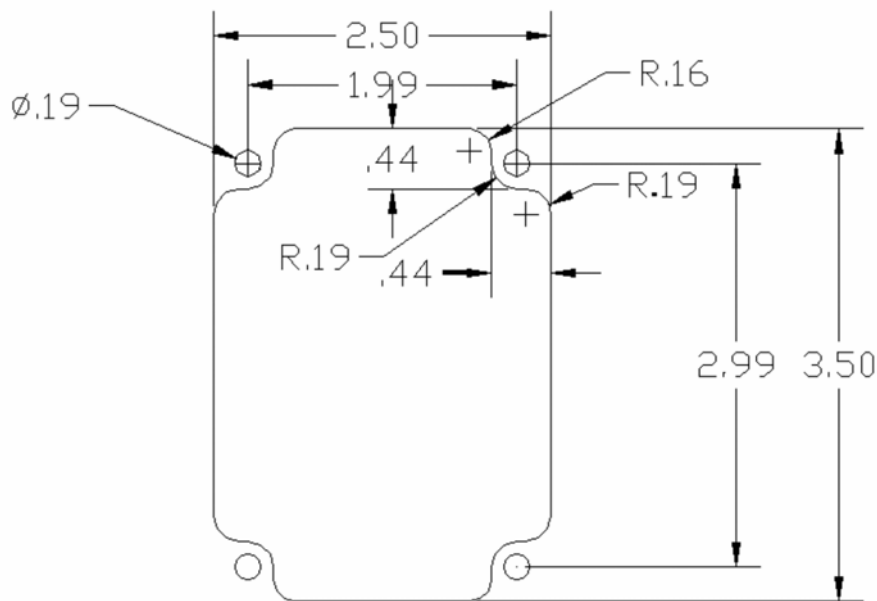

**Outer bezel dimensions.**

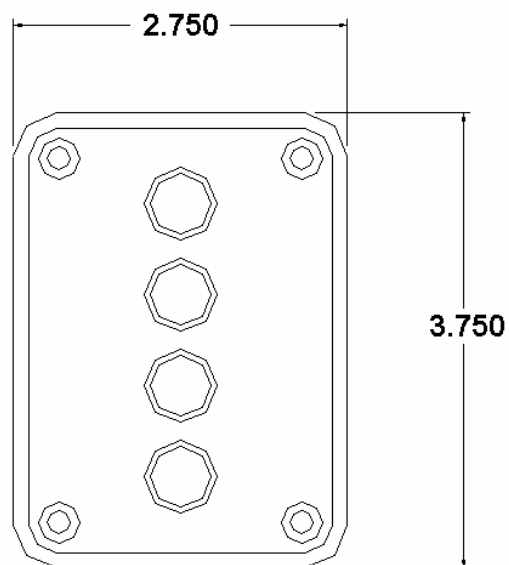

Before mounting the display and adhering the label insure that the unit is situated correctly (TOP is UP). Refer to the drawing for orientation.

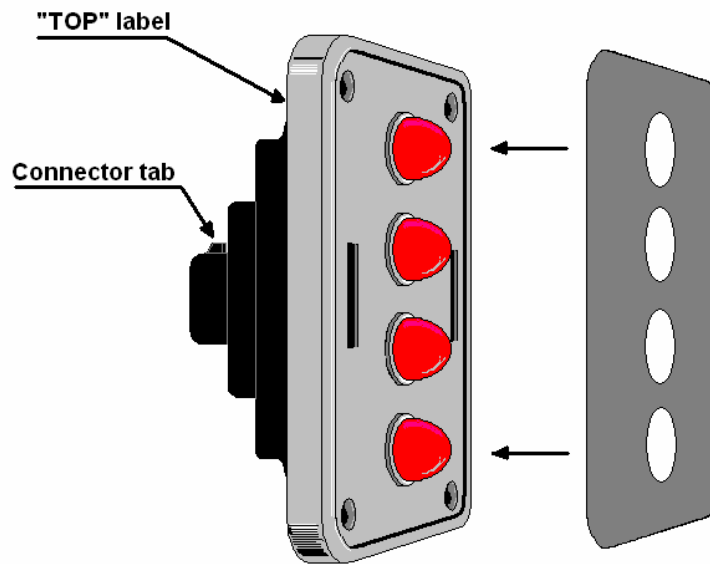

### Pressure Transducer

The transducer has a 1/4" NPT mount and must be mounted vertically as depicted to insure an accurate reading.

### Tank Level Gauge Transducer Installation

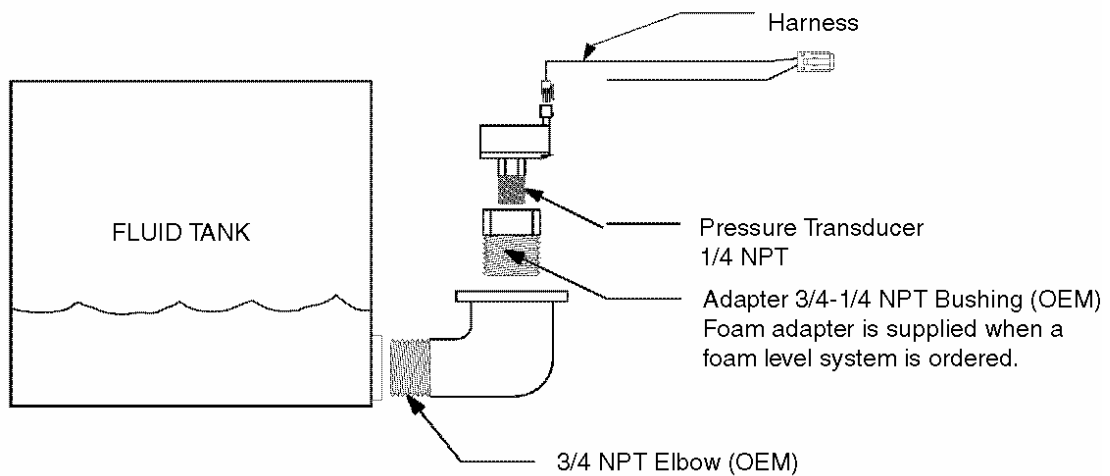

# Wiring

## Power and Ground

It is imperative that a system utilizing Master and Remote tank level units connected by the 1-wire data line have a common ground.

- Pin 1            Vehicle power
- Pin 2            Ground

## Dim Function

The LEDs on the tank level unit can be dimmed to a user selectable dim setting by applying vehicle voltage to the Dim display Input.

- Pin 3            Dim display input (VIGN)

## Transducer Connection

- Pin 6            Sensor power (+5V)
- Pin 7            Sensor signal
- Pin 8            Sensor ground

## 1-Wire Data Line

- Pin 4            Master to Remote data transfer line

CONNECTOR: AMP            PINS: AMP  
776286-1                      770520-1

POS	WIRE DESCRIPTION	
1	Power	(input)
2	Ground	(input)
3	Dim Display (VIGN)	(input)
4	Data	(I/O)
5	PLUG	
6	Sensor Power (+5V)	(output)
7	Sensor Signal	(input)
8	Sensor Ground	(output)

POS	WIRE DESCRIPTION
A	Sensor Power +5V (RED)
B	Sensor Ground (BLK)
C	Sensor Signal (WHT)

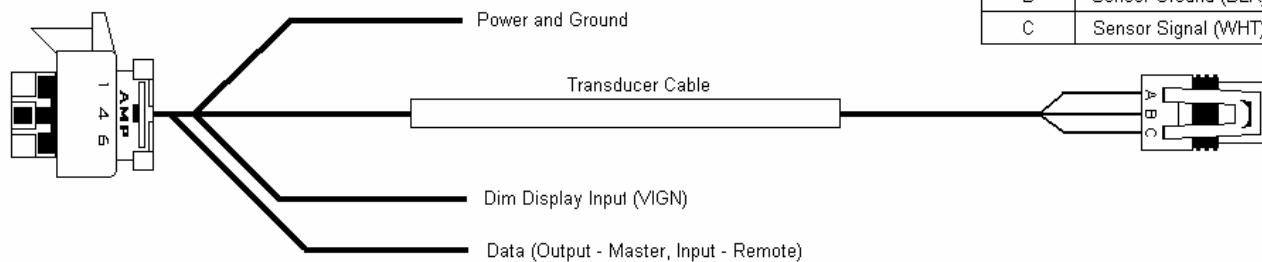

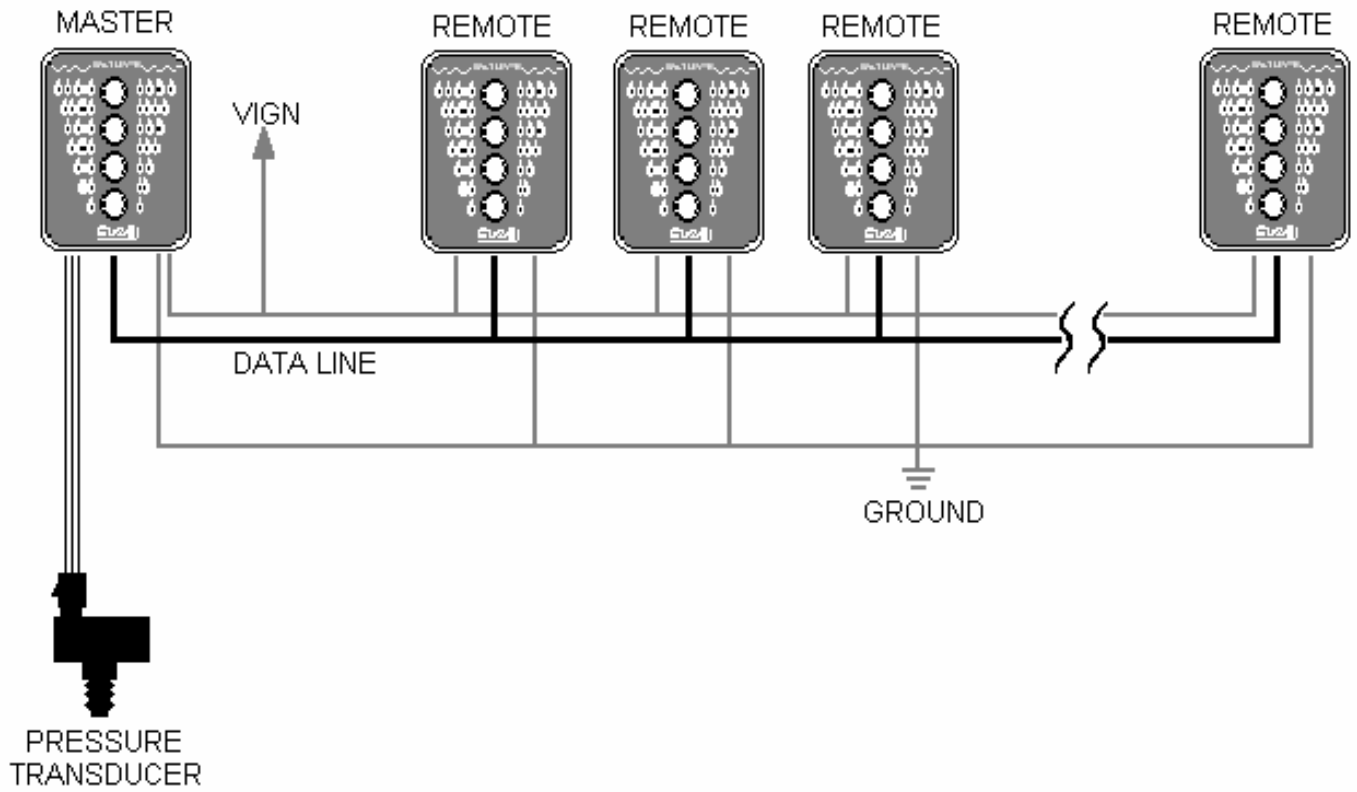

*Typical installation layout.*

# Calibration

The Intelli-Tank display can be calibrated four different ways: 1-point and 2-point (level calibration), 5-point and 9-point (volume calibration).

To enter calibration mode use a magnet and activate the magnetic switches in the order of the appropriate password.



The display has two magnetic switches (left and right). The magnetic switches are activated by using a magnet and touching the front of the display on either side of LED 2.



For best results the magnet should be positioned over the desired magnet approximately 2 inches from the front of the display, pushed directly to the front of the display, and then pulled back to the start position.



LEFT

RIGHT

The LEDs on the display will indicate which switch was activated (upper two LEDs = left switch, bottom LED = right switch) for approximately half a second and then the display will go blank.

The maximum time between magnetic switch activations is two seconds. If longer than two seconds have passed between activations the unit will resume normal operation and the password attempted will be reset.



Entering an invalid password will initiate a “wave off” pattern on the display. (Two center LEDs, two outer LEDs flashing quickly for 8 cycles.) The unit will then resume its normal operation and the user can attempt to re-enter the password.

Calibrate the unit by entering the desired point calibration –

- |         |                  |
|---------|------------------|
| 1 point | <b>RLLR LRRL</b> |
| 2 point | <b>RLLR LLRL</b> |
| 5 point | <b>RLLR LRLR</b> |
| 9 point | <b>RLLR RLLR</b> |

The calibration process can be cancelled at any time by activating the **LEFT** magnetic switch.

### 1 Point Calibration

1 point calibration only calibrates the full point. The empty calibration is always set to 0.55V (approximately 1.5 inches of liquid).

1. Make certain that the tank is FULL.
2. Enter the password **RLLR LRRL**. The unit will respond by flashing the top LED twice. The unit will then revert to normal operation by displaying FULL (all LEDs on).

### 2 Point Calibration

3. Enter the password **RLLR LLRL**. The unit will respond by flashing the two center LEDs twice. The unit will then begin cascading the LEDs from top to bottom (drip).
4. Make certain that the tank is EMPTY and then activate the **RIGHT** switch to store that point. The unit will flash the top LED and then turn on all four LEDs.
5. Fill the tank and then activate the **RIGHT** switch. The unit will respond by flashing the top LED then lighting the two center LEDs and then reverting to normal operation by displaying FULL (all LEDs on).

### 5 Point Calibration

1. Enter the password **RLLR LRLR**. The unit will respond by flashing the two center LEDs five times. The unit will then begin cascading the LEDs from top to bottom (drip).
2. Make certain that the tank is EMPTY and then activate the **RIGHT** switch to store that point. The unit will flash the top LED and then turn on the bottom LED.
3. Fill the tank to the one-quarter tank point and then activate the **RIGHT** switch. The unit will flash the top LED and then turn on the bottom two LEDs.
4. Fill the tank to the one-half tank point and then activate the **RIGHT** switch. The unit will flash the top LED and then turn on the bottom three LEDs.
5. Fill the tank to the three-quarter tank point and then activate the **RIGHT** switch. The unit will flash the top LED and then turn on all four LEDs.
6. Fill the tank to the full point and then activate the **RIGHT** switch. The unit will respond by flashing the top LED then lighting the two center LEDs and then reverting to normal operation by displaying FULL (all LEDs on).

## 9 Point Calibration

1. Enter the password **RLLR RLLR**. The unit will respond by flashing the two center LEDs nine times. The unit will then begin cascading the LEDs from top to bottom (drip).
2. Make certain that the tank is EMPTY and then activate the **RIGHT** switch to store that point. The unit will flash the top LED and then begin flashing the bottom LED.
3. Fill the tank to the one-eighth point and then activate the **RIGHT** switch. The unit will flash the top LED and then turn on the bottom LED.
4. Fill the tank to the one-quarter tank point and then activate the **RIGHT** switch. The unit will flash the top LED and then turn on the bottom LED and flash the second LED.
5. Fill the tank to the three-eighths point and then activate the **RIGHT** switch. The unit will flash the top LED and then turn on the bottom two LEDs.
6. Fill the tank to the one-half point and then activate the **RIGHT** switch. The unit will flash the top LED and then turn on the bottom two LEDs and flash the third LED.
7. Fill the tank to the five-eighths point and then activate the **RIGHT** switch. The unit will flash the top LED and then turn on the bottom three LEDs.
8. Fill the tank to the three-quarter point and then activate the **RIGHT** switch. The unit will flash the top LED and then turn on the bottom three LEDs and flash the fourth LED.
9. Fill the tank to the seven-eighths point and then activate the **RIGHT** switch. The unit will flash the top LED and then turn on all four LEDs.
10. Fill the tank to the full point and then activate the **RIGHT** switch. The unit will respond by flashing the top LED then lighting the two center LEDs and then reverting to normal operation by displaying FULL (all LEDs on).

Calibration data is saved in non-volatile EEPROM and the unit does not need power to retain calibration data.

Calibration automatically makes the unit a master if the calibration is valid. An invalid calibration is determined if any point is not at a higher level than the previous, or if the transducer voltage falls outside of the valid minimum (.4V) or maximum (4.8V) range. An invalid calibration is acknowledged by giving the “wave off” and if this was a master unit previously will alterna-flash the outer two LEDs, while a Remote will revert to Remote operation.

# Self test and Dim

## Dimming the Display

The display can be dimmed by applying VIGN to pin 3 (Dim Display input). To select the dim level of the display use the magnetic switches to enter the password

### RLLR LLLR

all of the LEDs will come on. Hold the magnet against the **RIGHT** switch and the display will either brighten or dim. Release the magnet and again hold it against the **RIGHT** switch and the display's brightness will move in the opposite direction. When the dim level is at the desired point activate the **LEFT** switch. Each unit has its own calibrated dim level and dim input.

## Self Testing the Unit

The Tank Level can check its hardware for proper operation by entering the password

### RLLR LLRR

the unit will then cycle each LED on individually starting with the bottom LED and then all LEDs will come on and begin flashing between full bright and the calibrated dim level for 5 seconds. The display will then show the condition of the self test for 5 seconds.

A **PASS** condition is indicated when only the top LED (LED 4) is on.

A **FAIL** condition exists if LED 4 is off and any other LED is on.

LED 3 ON	Memory failure.
LED 2 ON	Data line error.
LED 1 ON	Transducer signal line out of tolerance or shorted to +5V.
LED 1 Flashing	Transducer signal shorted to ground (too low).

*If the self test password is used on a Master unit all Remote units will also perform their self test.*

# Passwords

RLLR LRRL	1 point calibration
RLLR LLRL	2 point calibration
RLLR LRLR	5 point calibration
RLLR RLLR	9 point calibration
RLLR LLRR	Self test
LRLR LRLR	Configure unit as Remote unit
RLLR LLLR	Configure dim level

## Software revision check

Hold a magnet on the **LEFT** magnetic switch while powering the unit. The LEDs will display the software revision. (Use the chart below to decipher).

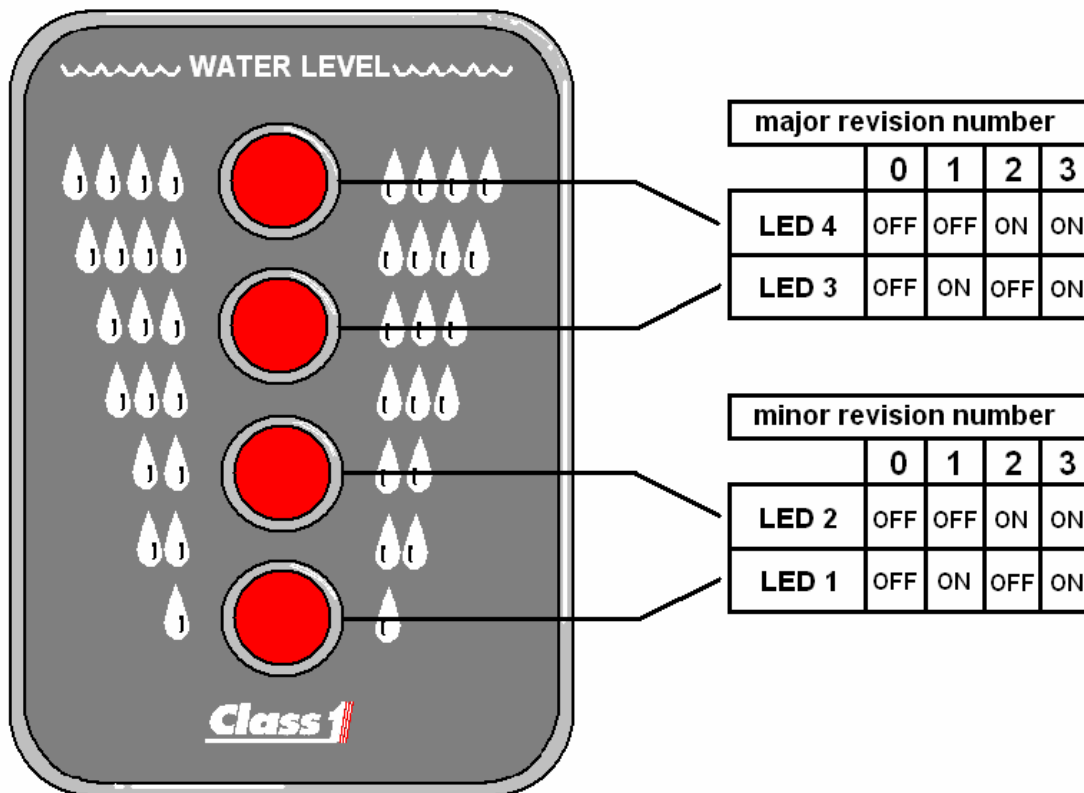

Example. (LED 4 – OFF, LED 3 – ON, LED 2 – OFF, LED 1 – ON) = Ver 1.1

# Troubleshooting

Condition	Evaluate
Bottom two LEDs alternate flashing. Unit fails self test, LED 1 flashing.	Check transducer wiring. Ensure +5V at pin A, ground at pin B and at least .4V at pin C (Signal).
Top two LEDs alternate flashing. Unit fails self test, LED 1 on.	Check transducer wiring. Ensure +5V at pin A, ground at pin B and no more than 4.8V at pin C (Signal).
Middle two LEDs alternate flashing.	Perform self test. If it fails with LED 3 on replace unit.
Outer two LEDs alternate flashing.	Try to recalibrate. If condition remains, check if transducer signal voltage (pin C) changes as tank level increases. If it doesn't, replace transducer. If it does, verify depth of tank. It may be impossible to calibrate a tank with a depth of less than 6 inches.
Bottom two and Upper two LEDs alternate flashing.	The unit is configured as a Remote. If it required to be a Master then recalibrate. If the unit is required to be a Remote check Data line (Pin 4) continuity and insure line is not grounded.
No LEDs on.	Check power (Pin 1) and ground (Pin 2) connection.
Master Tank level display does not change when actual tank level is changing.	Check transducer wiring. Ensure transducer signal voltage (Pin C) is varying. If it does, check for same signal changes at Pin 6 of tank level connector (if it is not the same repair wiring). If signal is good at both locations try re-calibrating.
Remote Tank level display does not follow Master display.	Perform self test. If self test is good, check pin 4 (data line) for continuity and insure it is not shorted to ground or power. Insure data line is not routed near noisy power or RF sources.
Unit fails self test, LED 2 on.	Check pin 4 (data line) for continuity and insure it is not shorted to ground or power.
No passwords are accepted.	If the display issues the "wave off" after entering a password, insure the unit is installed upright. During power-up the display should cycle on each LED individually starting with the bottom LED.  Check that the left and right magnetic switches are recognized by activating each switch and verifying that the associated LEDs illuminate.

Condition	Evaluate
The bottom two LEDs are on and occasionally they go out and the top two flash and then return to the bottom two LEDs on (or vice-versa). (REMOTE).	<p>Check for large noise spikes on the data line.</p> <p>Insure that the unit's ground potential is the same as the Master's.</p> <p>Insure that the data line is not chaffed and making contact with other electrical wires.</p>
The points calibrated seemed to have changed.	<p>Self test the unit to check for any malfunctions.</p> <p>Check the pressure transducer for problems.</p> <p>Recalibrate the unit and take a voltage reading from the transducer (pin 7 on the unit's connector) at each calibration point. When the calibration points again look wrong check the voltages at those points and determine if they are the same as the voltage reading taken during calibration.</p>
Unit will not dim display.	<p>Insure the Dim input voltage on Pin 3 is at least 9V. Recalibrate dim setting (<b>RLLR LLLR</b>). If unit does not dim LEDs while in dim calibrate mode, replace unit.</p>
The two top amber LEDs are flashing together.	<p>A calibration was started on the unit but not completed correctly. Set the unit to a REMOTE unit (LRLR LRLR) or calibrate it as a MASTER (follow calibration steps exactly).</p>
Top LED is the only LED illuminated.	<p>The unit has had a memory error.</p> <p>Attempt to set the unit back to REMOTE or MASTER as required.</p>

# Notes

55	Remote
91	Dim adjust
92	2-point cal
93	Self test
95	5-point cal
96	1-point cal
98	Default master
99	9-point cal

