

INSTALLATION INSTRUCTIONS:

- 1 REMOVE PLASTIC COVERING ON GAUGE GASKET ADHESIVE.
- 2 INSERT GAUGE (ITEM 1) INTO SHEET METAL PANEL.
- 3 IF NECESSARY, APPLY **ONLY LOCTITE 425** (AS SHOWN IN DETAIL A) ACCORDING TO THE CHART BELOW:

GAUGE SIZE	LOCTITE 425 DROPS
60mm (2")	2
80mm (3")	2
100mm (4")	3

- 4 ATTACH GAUGE NUT (ITEM 2) AND HAND TIGHTEN (USE NON-MARRING TOOLS IF NECESSARY).
- 5 ATTACH APPROPRIATE FITTING TO GAUGE INTERNAL STEM, AS REQUIRED (SEE DETAIL B).

TIGHTEN FITTING BY GRIPPING FLAT SURFACES ON GAUGE INTERNAL STEM.

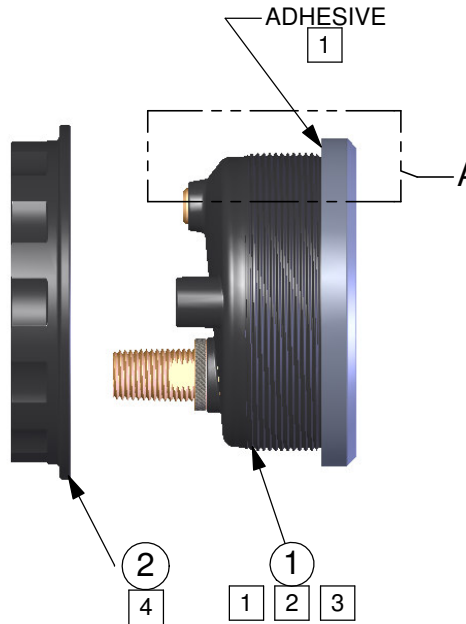
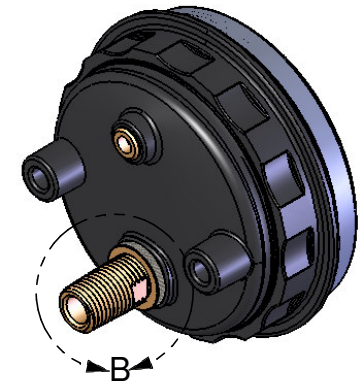

DETAIL B
SCALE 1 : 1.5

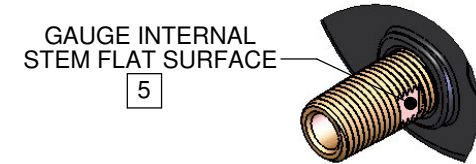

USE FLAT SURFACES WHEN TIGHTENING OR LOOSENING GAUGE FITTINGS

IF NECESSARY, APPLY LOCTITE 425 AT BEGINNING OF THREADS ON GAUGE CASE

DETAIL A
SCALE 1 : 1.5



ITEM	PART	DESCRIPTION	QTY
2	NUT	60mm, 80mm, or 100mm NUT	1
1	GAUGE	60mm, 80mm, or 100mm GAUGE	1

DRAWING NOTES:
UNLESS OTHERWISE SPECIFIED
1. ALL dimensions are in inches
2. Do not scale drawing
3. Decimal Tolerance
X.XX = +/- .01
X.XXX = +/- .005
X.XXXX = +/- .0005
4. Angle Tolerance .5 degrees.

Class 1 A unit of **IDEX** CORPORATION
607 N.W. 27th Ave.
Ocala, Florida 34475
Phone: 352-629-5020
FAX: 352-629-2902

**METRIC GAUGE
INSTALLATION DRAWING**

CAGE IDENT. NO.	COMPLETED	DRAWN	CHECKED	APPROVED	PROJECT
06CG4	12/01/06	AJG	--	--	--
SIZE A	DRAWING NUMBER 115913				REV -
SCALE 1:2					SHEET 1 OF 1

REV	DATE	BY	ECR	DESCRIPTION
-	12/01/06	AJG	N/A	ORIGINAL RELEASE